

# BELLE STATUS-Report

CP-Verletzung  $B^0 \bar{B}^0$

WIENER BEITRÄGE

Upgrade des **SVD 2.0**  
Silizium Vertex Detektors

Messung von  $V_{ub}$



STATUS-Report

5. Februar 2002



# KEKB Collider

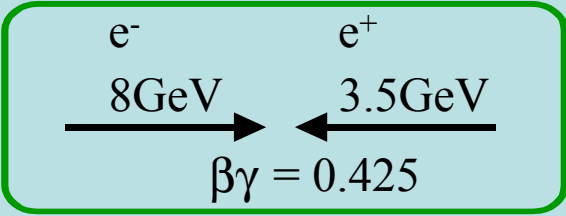

$\mathcal{L} = 5.6 \times 10^{33} \text{ cm}^{-2} \text{ sec}^{-1}$   
 Design =  $10^{34} \text{ cm}^{-2} \text{ sec}^{-1}$

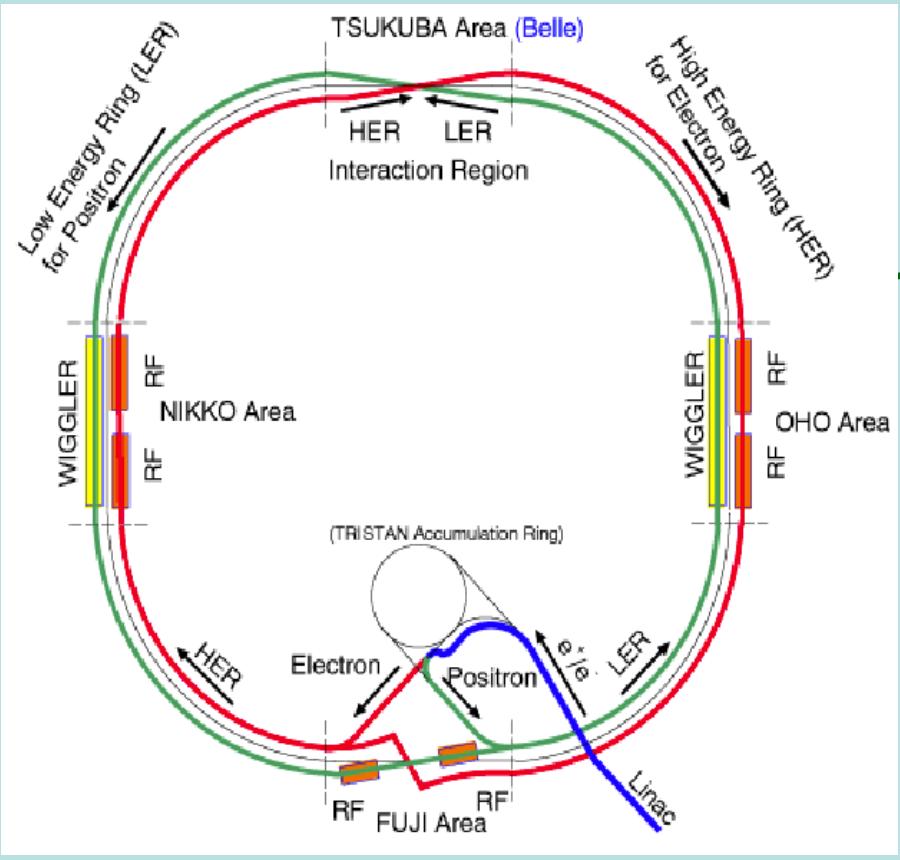

## STATUS-Report

5. Februar 2002



# Belle

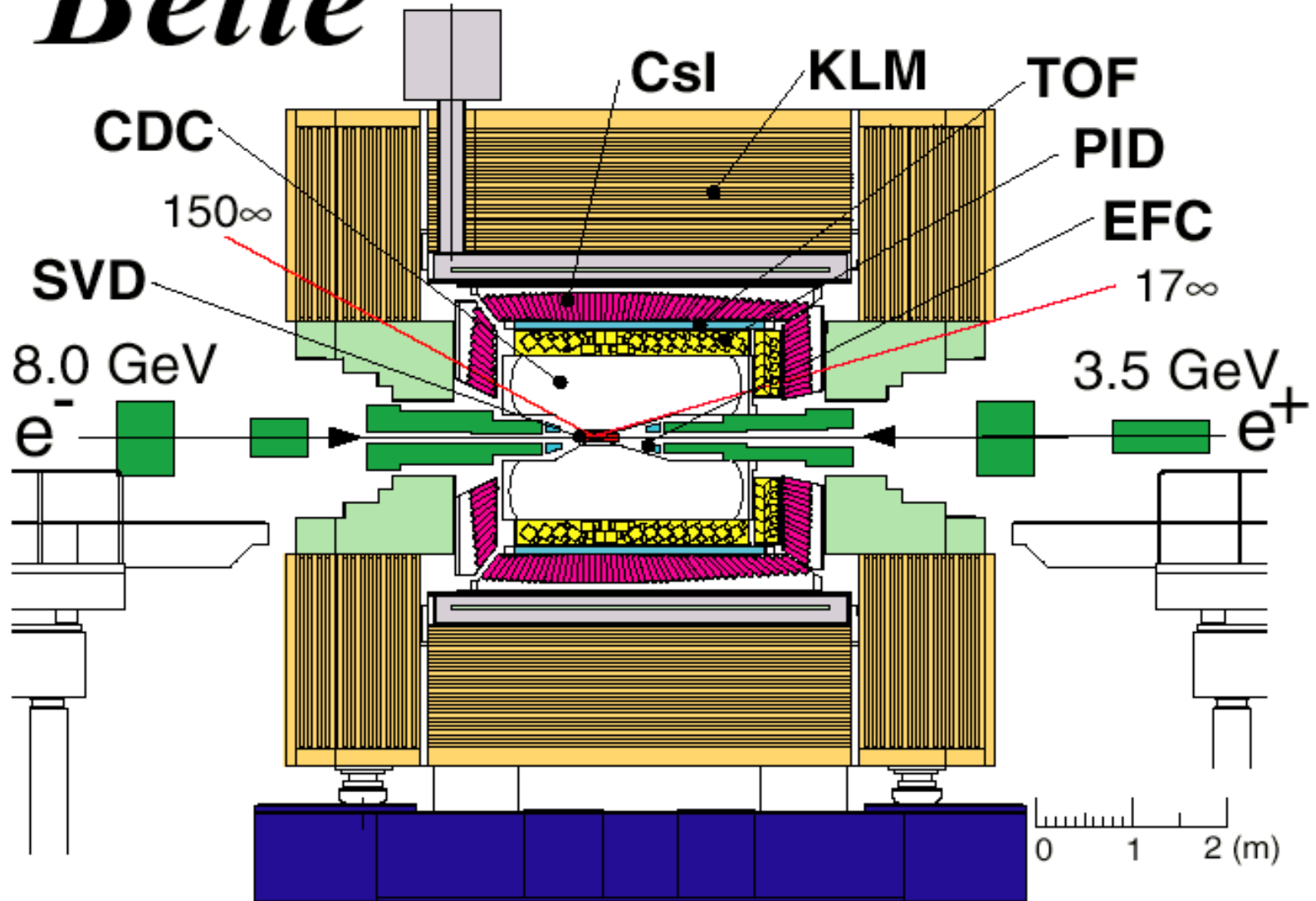

## STATUS-Report

5. Februar 2002



# SM-theory for mixing-induced CP-violation

$$A(\Delta t) \equiv \frac{\Gamma(\overline{B}_d^0 \rightarrow f_{CP}) - \Gamma(B_d^0 \rightarrow f_{CP})}{\Gamma(\overline{B}_d^0 \rightarrow f_{CP}) + \Gamma(B_d^0 \rightarrow f_{CP})} = -\xi_f \sin 2\phi_1 \sin \Delta m_d \Delta t,$$

$$\Delta t \equiv t_{CP} - t_{tag}$$

$f_{CP}$  : CP eigenstate

$\Gamma(\overline{B}_d^0 (B_d^0) \rightarrow f_{CP})$  : decay rate for a  $\overline{B}_d^0 (B_d^0)$  to  $f_{CP}$  at  $\Delta t$

$\xi_f$  : CP-eigenvalue of  $f_{CP}$

$$\phi_1 \equiv \pi - \arg \left( \frac{-V_{tb}^* V_{td}}{-V_{cb}^* V_{cd}} \right) = \beta$$

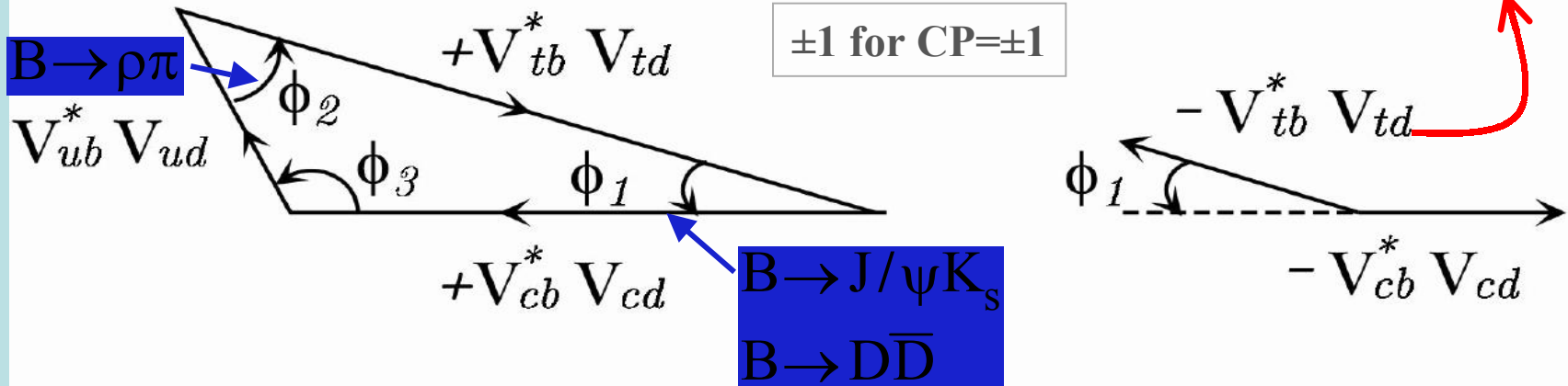

## Kobayashi-Maskawa-Ansatz in the Standard Model

STATUS-Report

5. Februar 2002



$\sin 2\phi_1 : B \rightarrow f_{CP} + B \leftrightarrow \bar{B} \rightarrow f_{CP} \text{ Interferenz}$

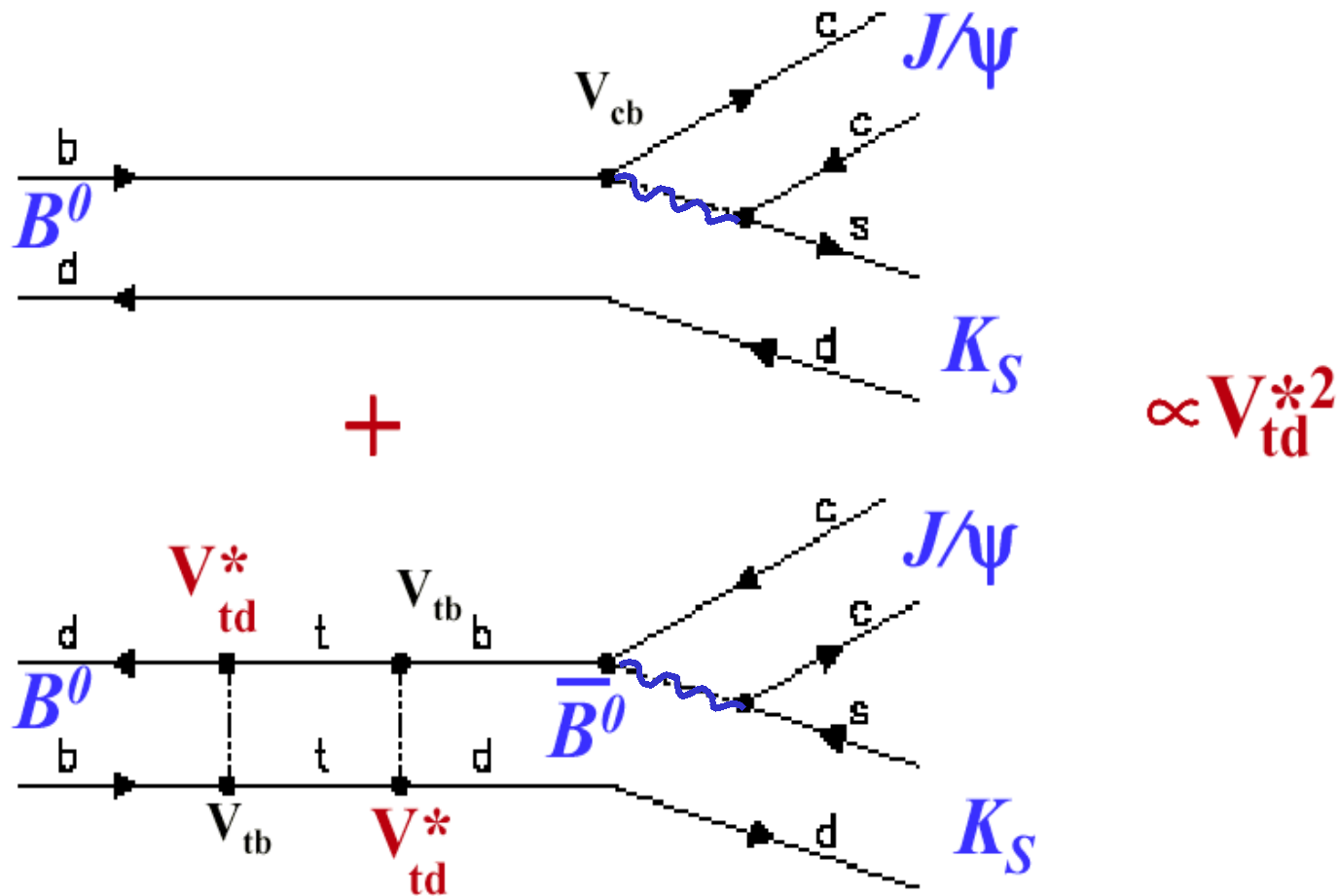

STATUS-Report

5. Februar 2002



# Was wird wirklich gemessen?

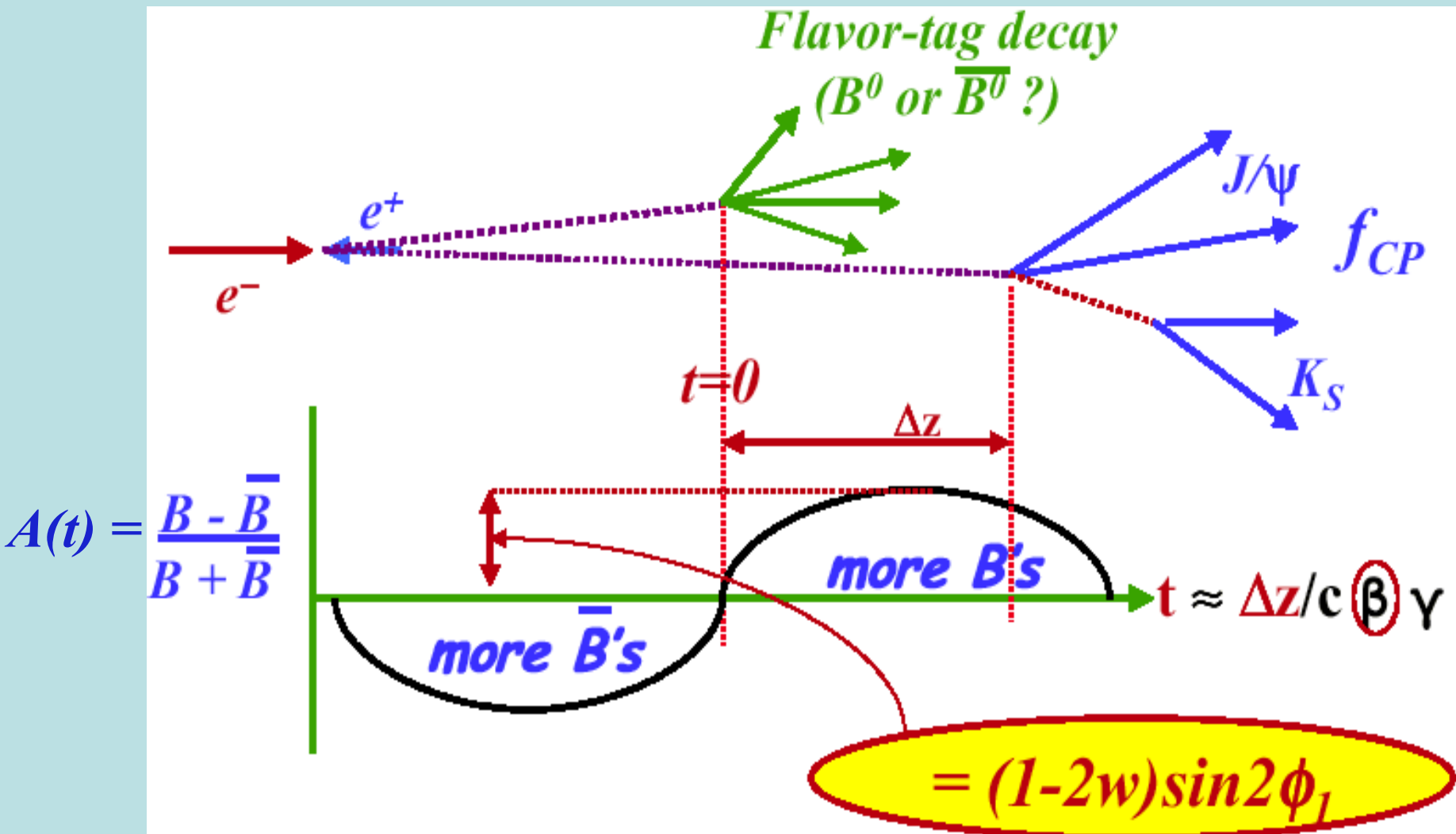

# SVD.2-Seitenansicht

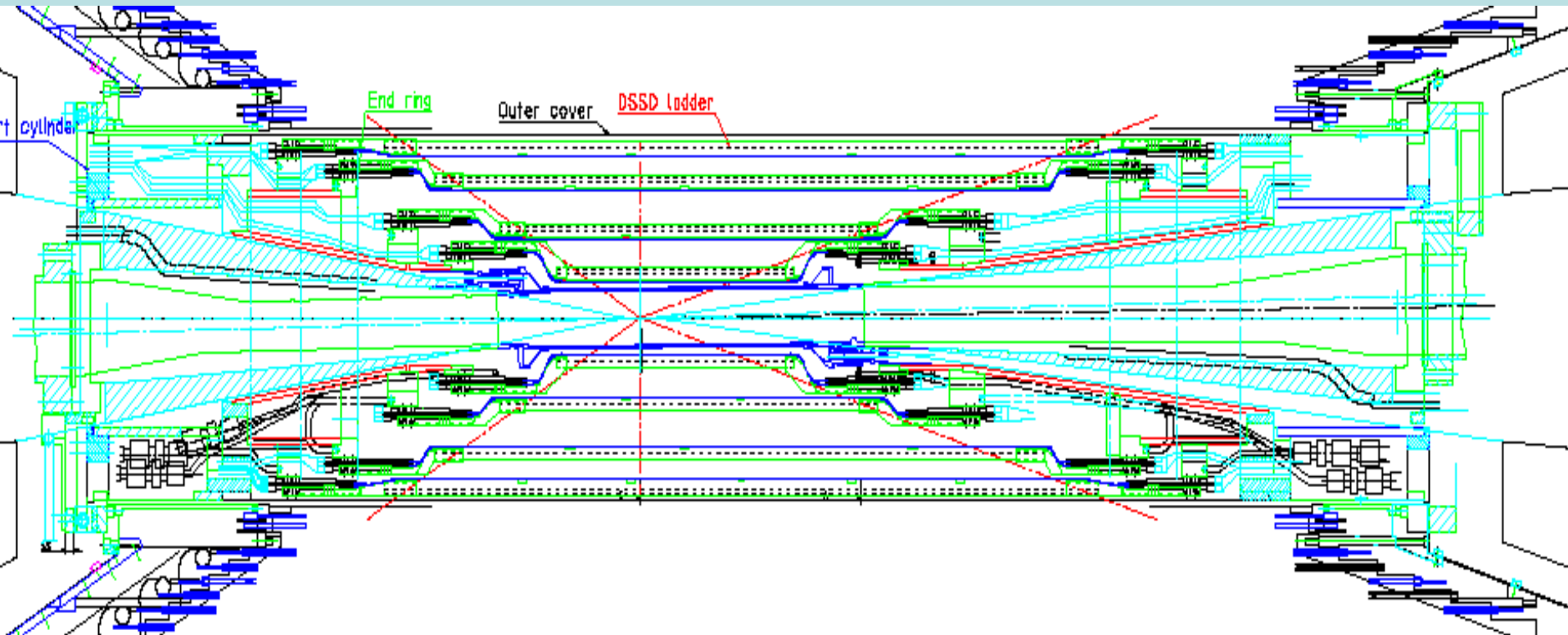

**STATUS-Report**

5. Februar 2002



# SVD 2.0 Detector

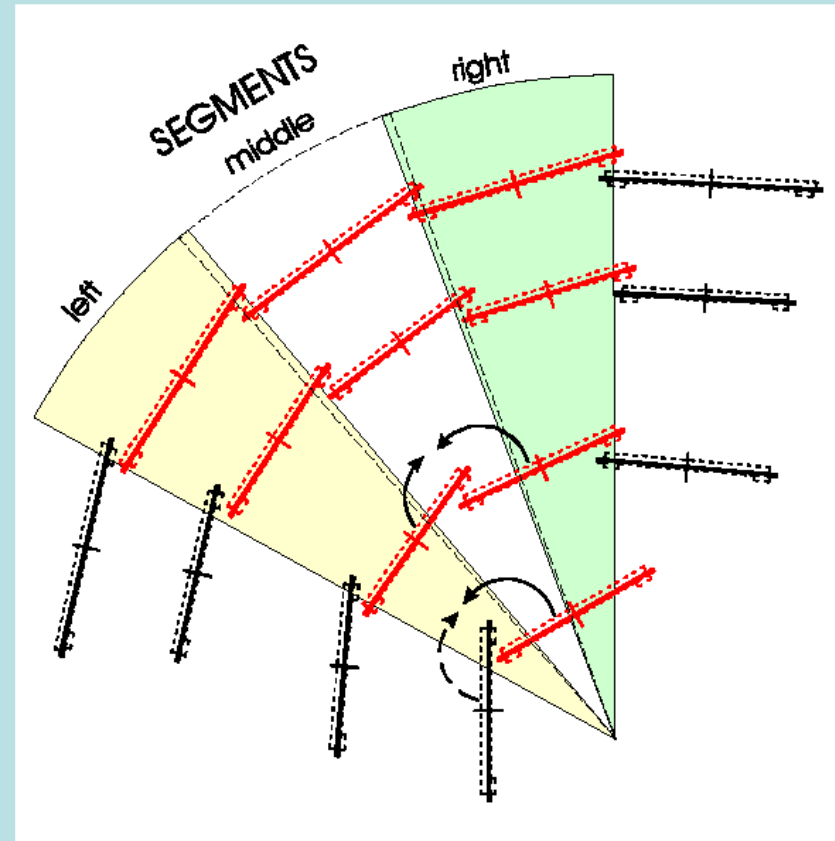
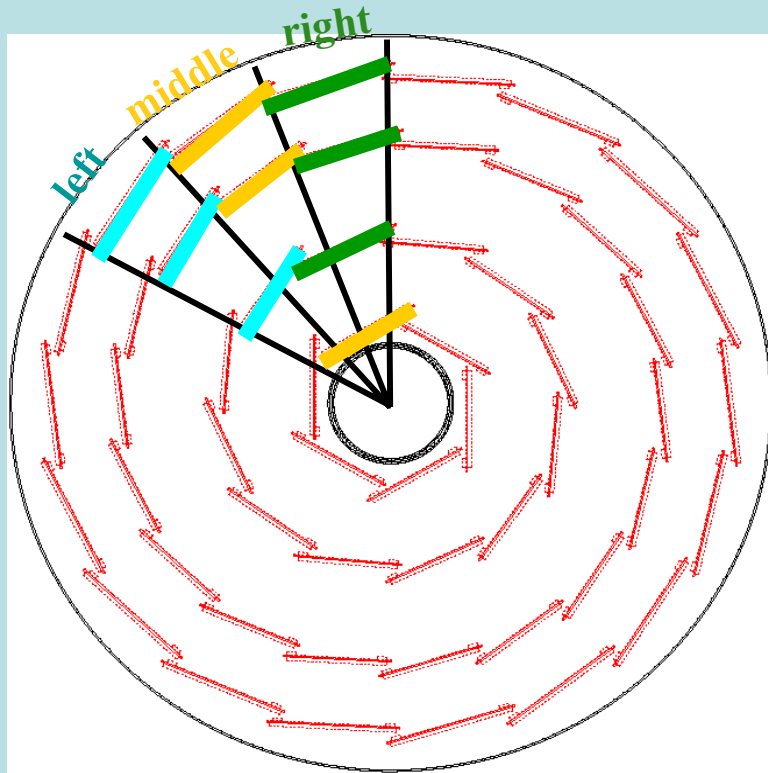

**STATUS-Report**

5. Februar 2002



# Readout Electronics

Good news no change from last progress meeting

## System Overview

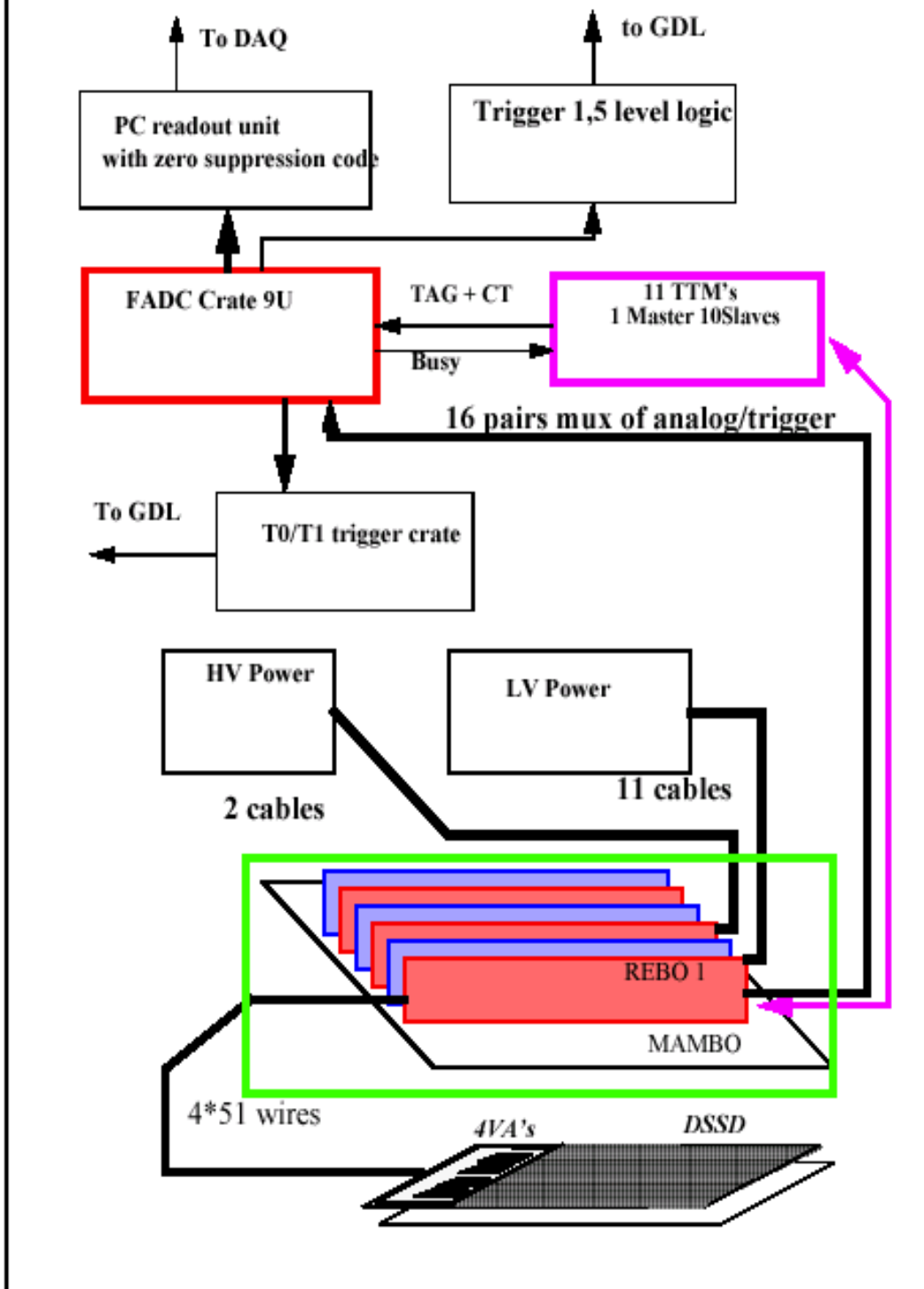

STATUS-Report

5. Februar 2002



# Wiener Beitrag

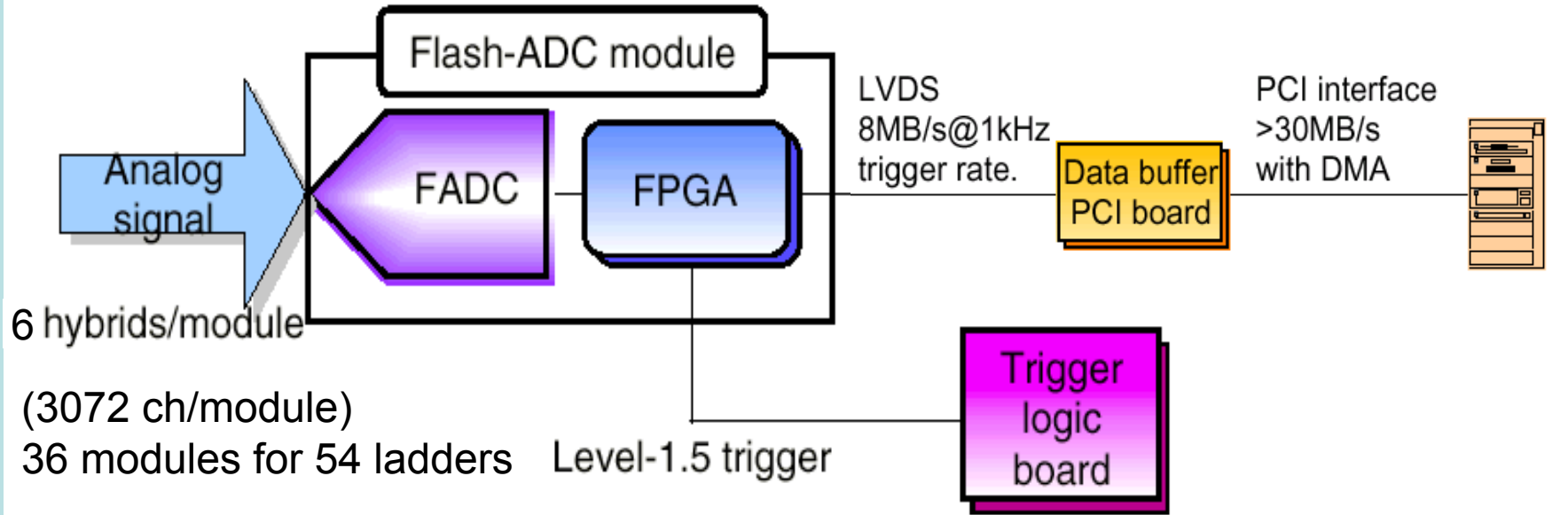

## FPGA algorithm for L1.5 trigger

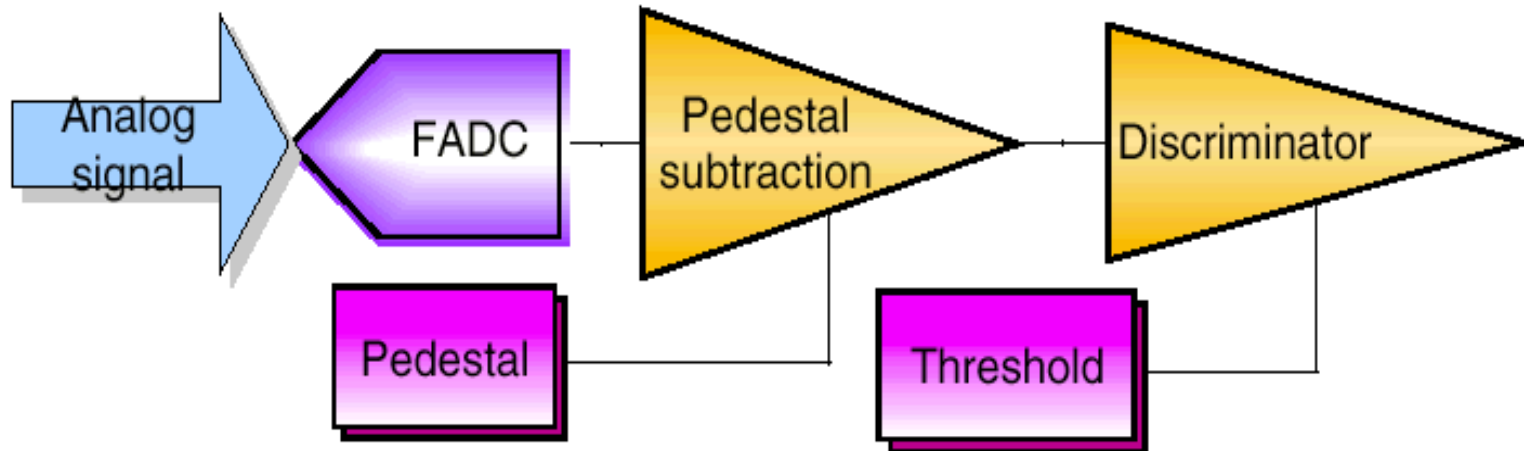

STATUS-Report

5. Februar 2002



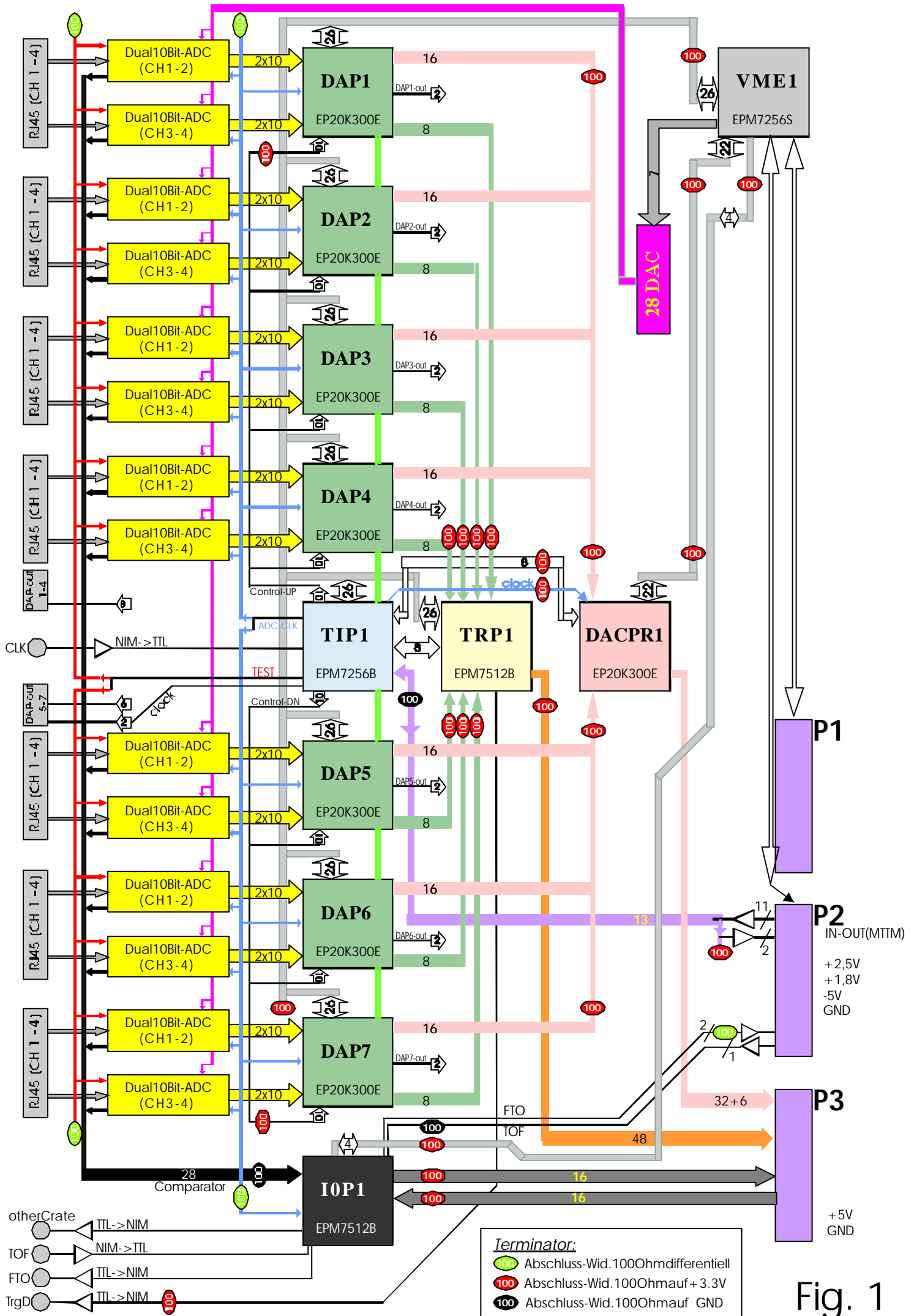
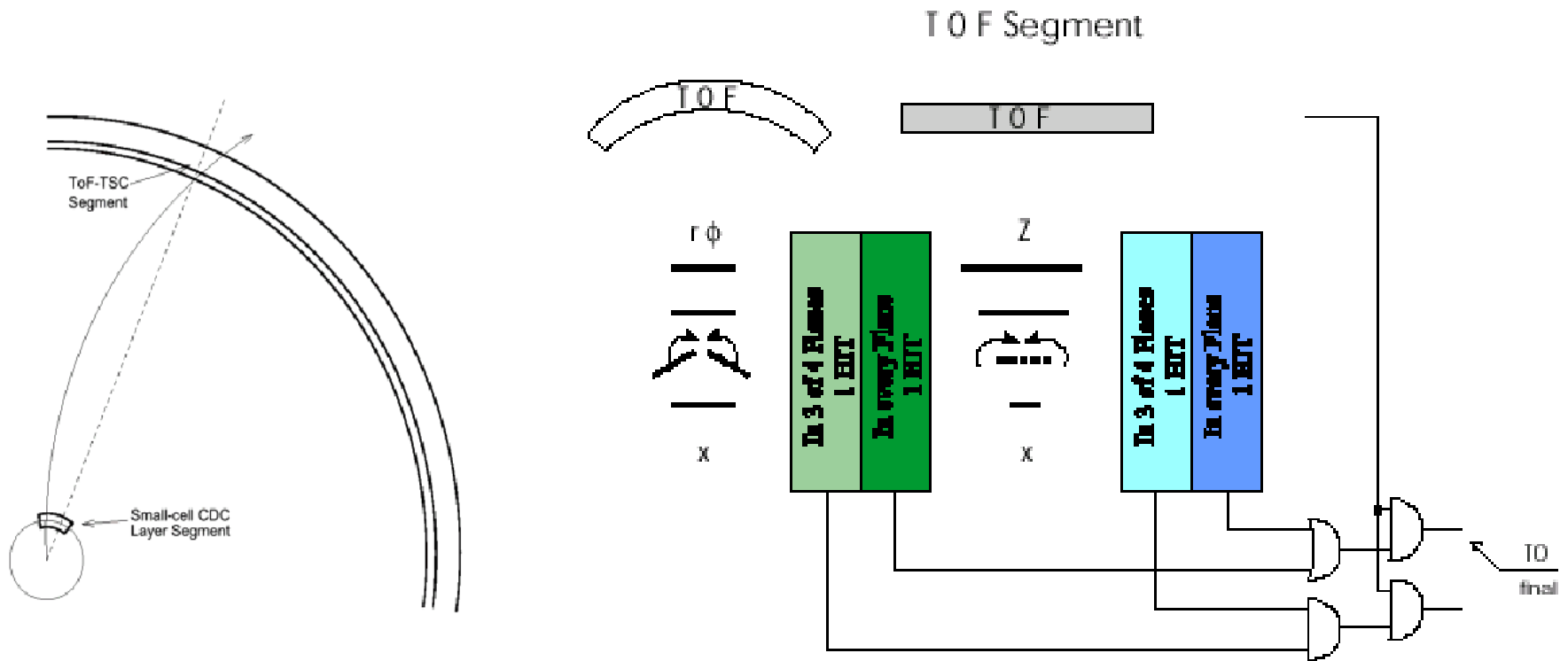

Fig. 1

# Level 0-Trigger



**Koinzidenz von TOF, CDC, SVD**

**STATUS-Report**

5. Februar 2002



# LEVEL 0: z-TRIGGER

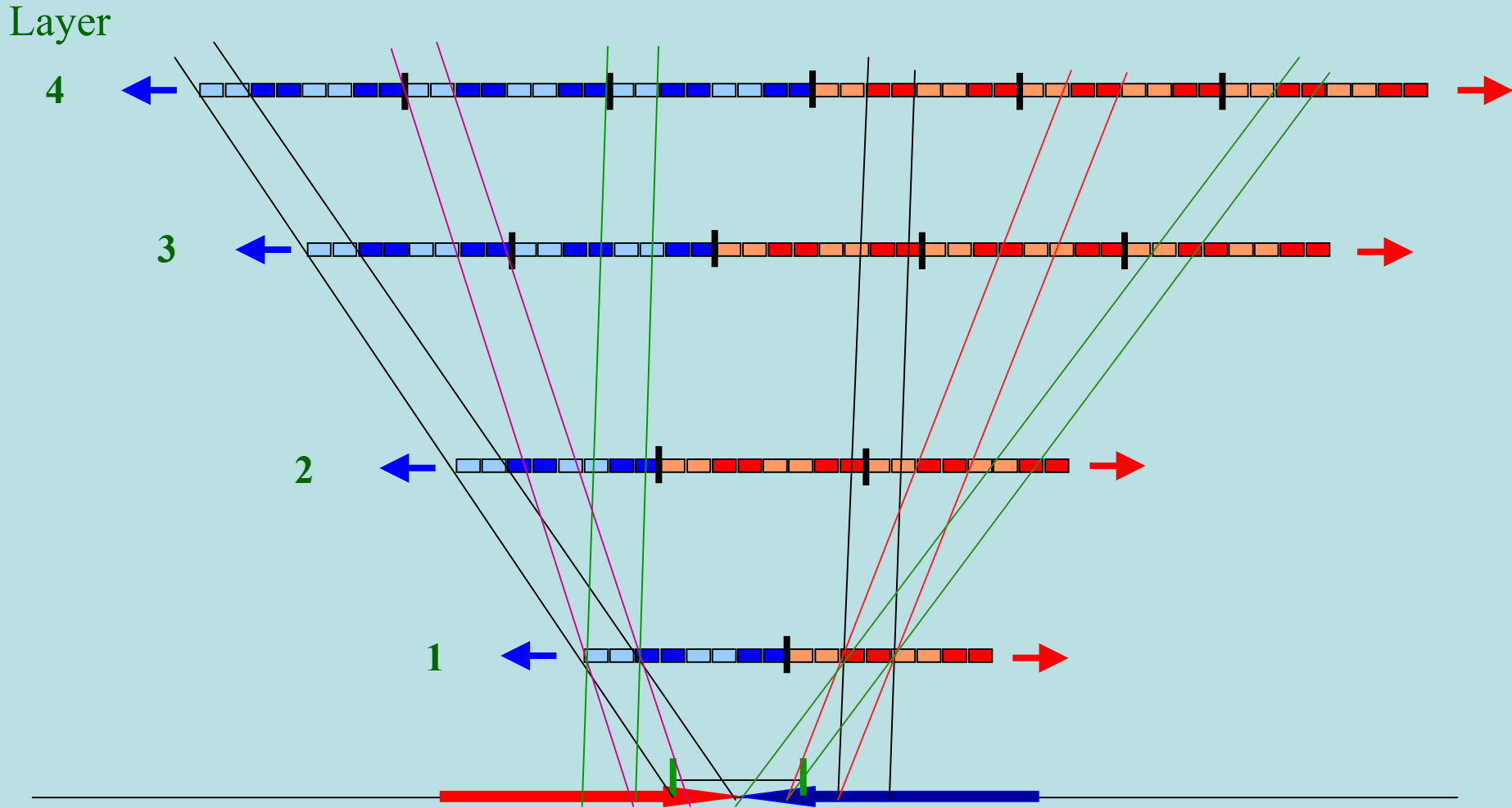

STATUS-Report

5. Februar 2002



# Rejection Power des z-Triggers

## Level 0

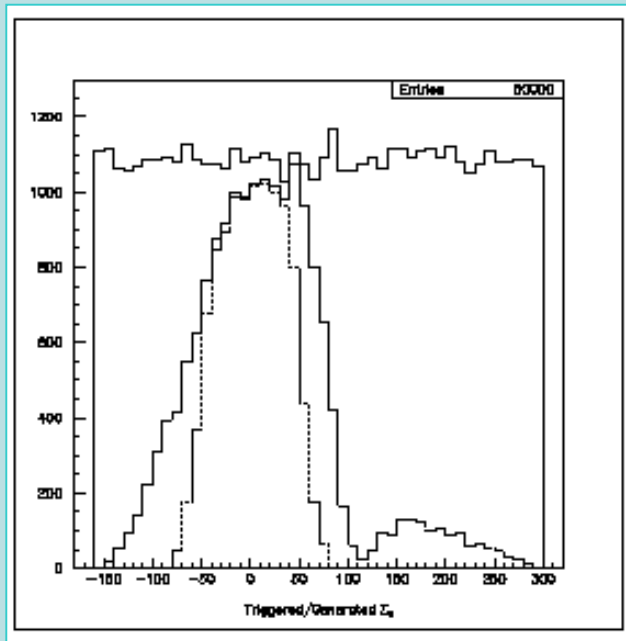

## Level 1.5

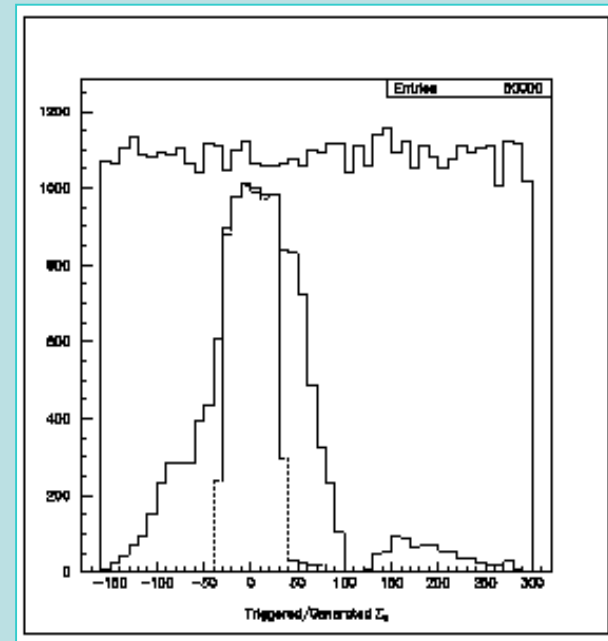

**Beamweite  $\pm 30\text{mm}$**

**STATUS-Report**

5. Februar 2002



# Wiener Beitrag

Bestimmung von  $V_{ub}$ :  $\bar{B}^0 \rightarrow \pi^+ l^- \bar{\nu}$

$Y(4s) \Rightarrow B\bar{B}$

Messung aller  
Impulse und  
Energien aller  
rekonstruierten  
Teilchen



„ $P_{\nu}(\text{rek-gen})$ “  
= 0

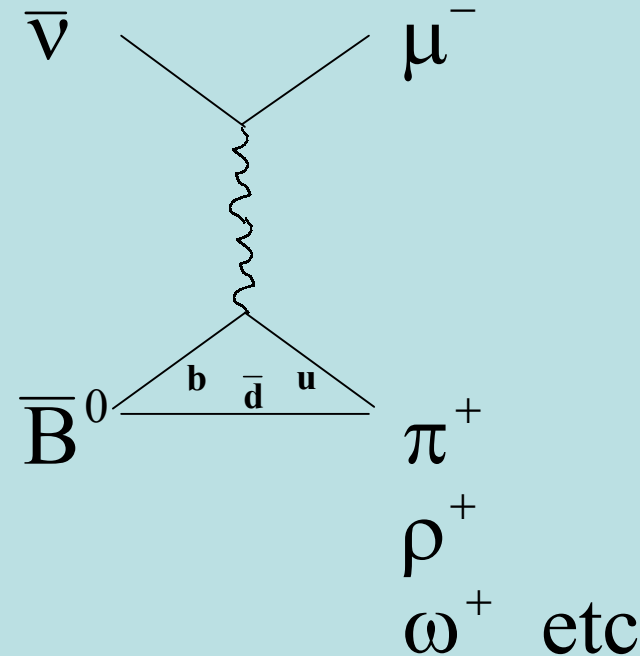
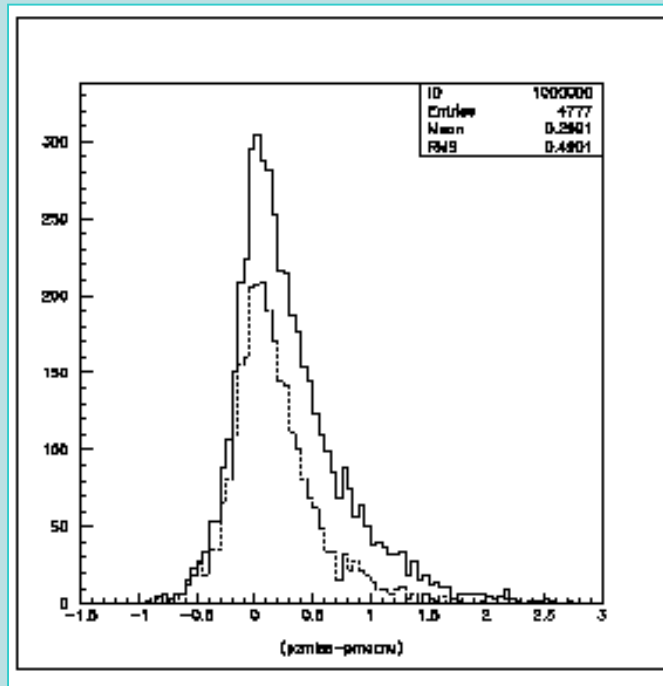

STATUS-Report

5. Februar 2002



# Wiener Beitrag

Bestimmung von  $V_{ub}$ :  $\bar{B}^0 \rightarrow \pi^+ l^- \bar{\nu}$

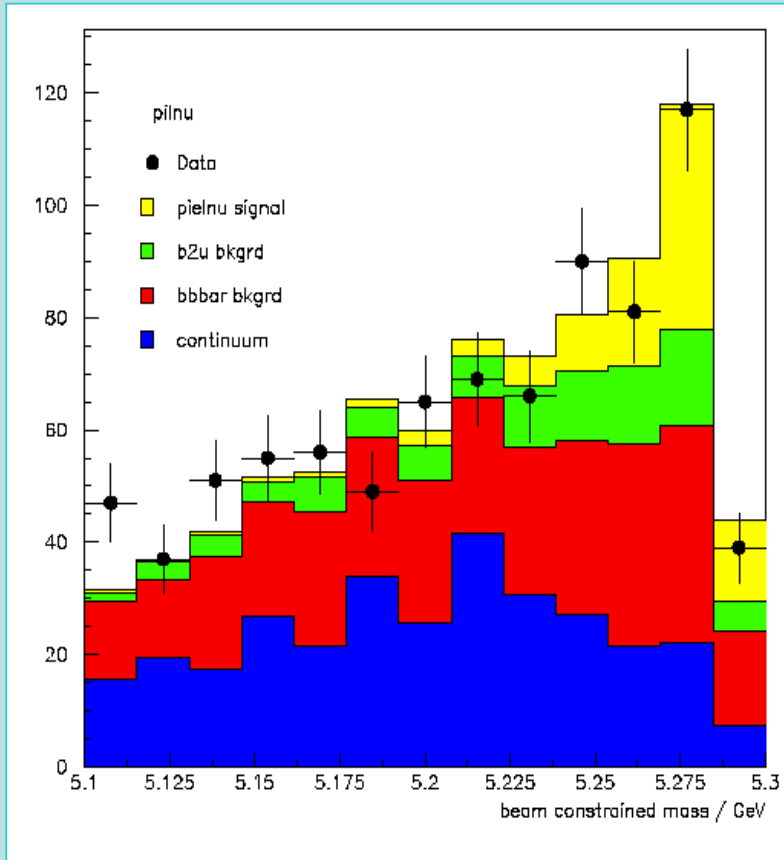

$$m_{bc} = \sqrt{(\mathbf{E}_{CM}/2)^2 - (\vec{p}_\pi + \vec{p}_l + \vec{p}_\nu)^2}$$

$> 5.25 \text{ GeV}$

$$\Delta E = E_\pi + E_l + E_\nu - E_{CM}/2 < 0.3 \text{ GeV}$$

reject continuum

$$|\mathbf{E}_{\text{miss}}^2 - \vec{p}_{\text{miss}}^2| < 2 \text{ GeV}^2$$

4 Variablen zum Diskriminieren:

$\vec{p}_\pi, \vec{p}_l, \text{Vertex prob}(l, \pi), \cos \Theta_{B, \pi l}$



STATUS-Report

5. Februar 2002



# Wiener Beitrag

Bestimmung von  $V_{ub}$  inklusiv:  $\bar{B}^0 \rightarrow \pi^+ l^- \bar{\nu}$

$m_X^2$  distribution (normalized)

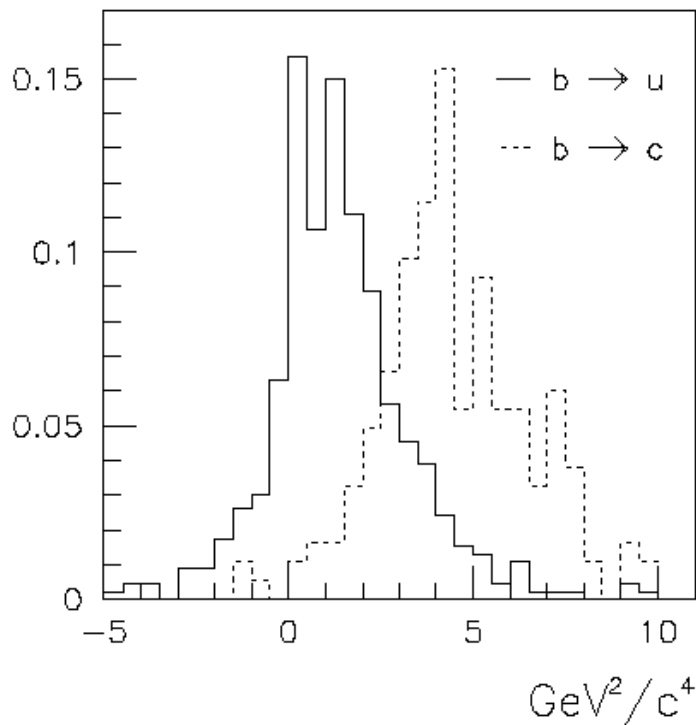

$$m_X^2 < 2 \text{ GeV}^2$$

$$V_{ub} \sim 0.1 \times V_{cb}$$

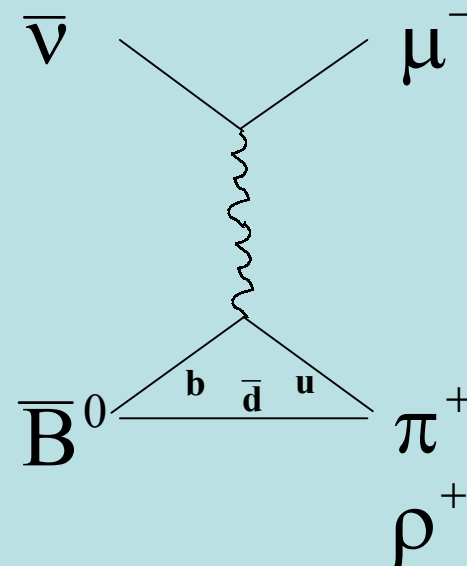

STATUS-Report

5. Februar 2002





# Compare with CKM constraints

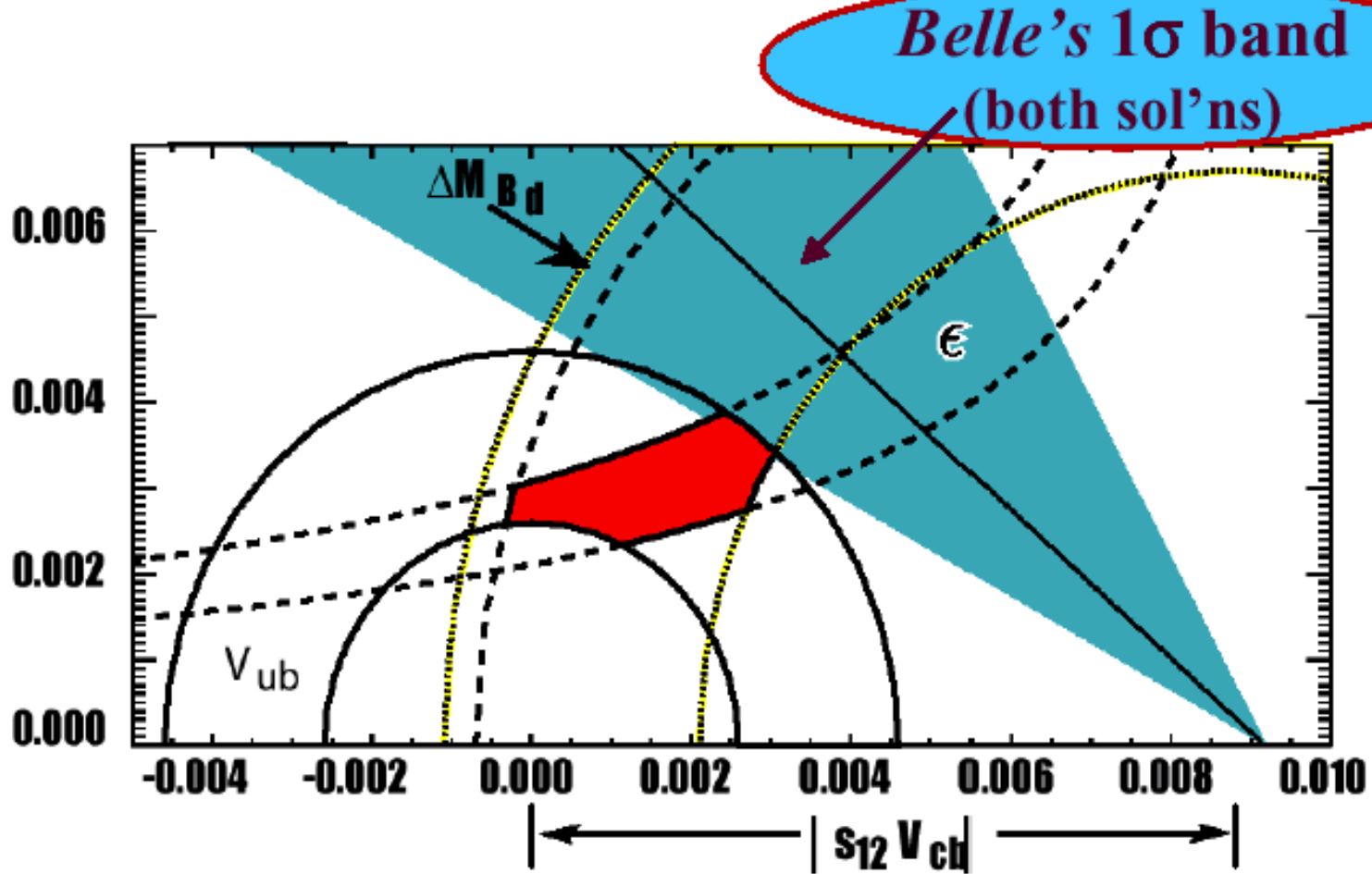

STATUS-Report

5. Februar 2002



# Zusammenfassung

- CP im B-Zerfall sehr stark verletzt

**>6σ!!**

- $\sin 2\phi_1$  nahe 1

$$0.99 \pm 0.14 \pm 0.06$$

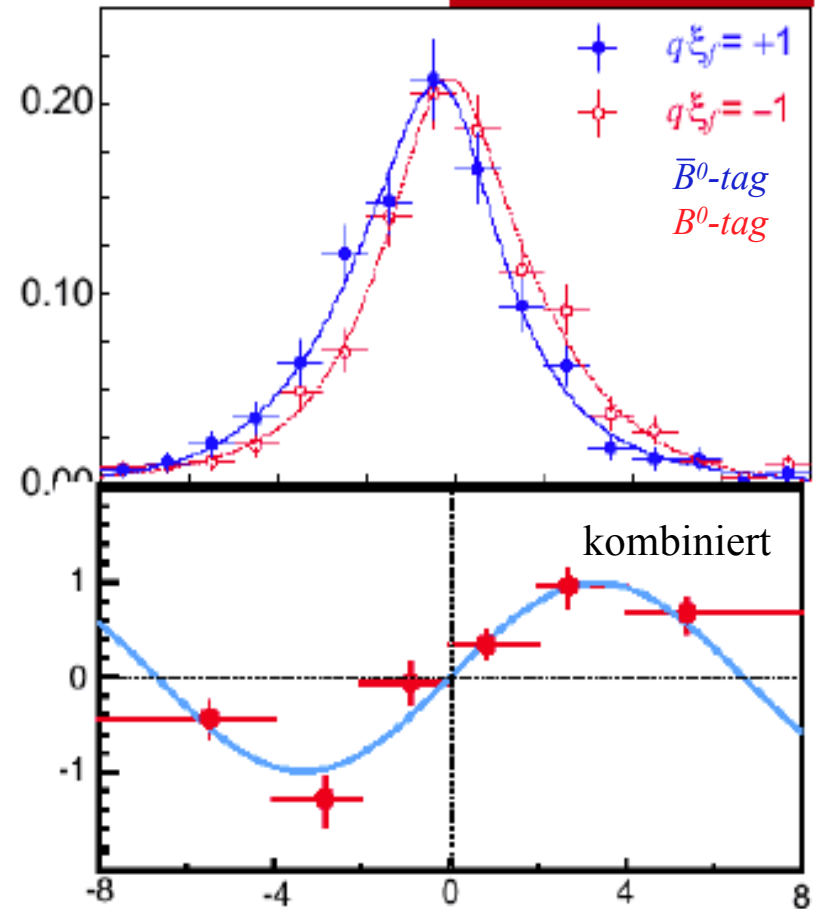

STATUS-Report

5. Februar 2002

$\Delta t$  (ps)





# Compare with other experiments

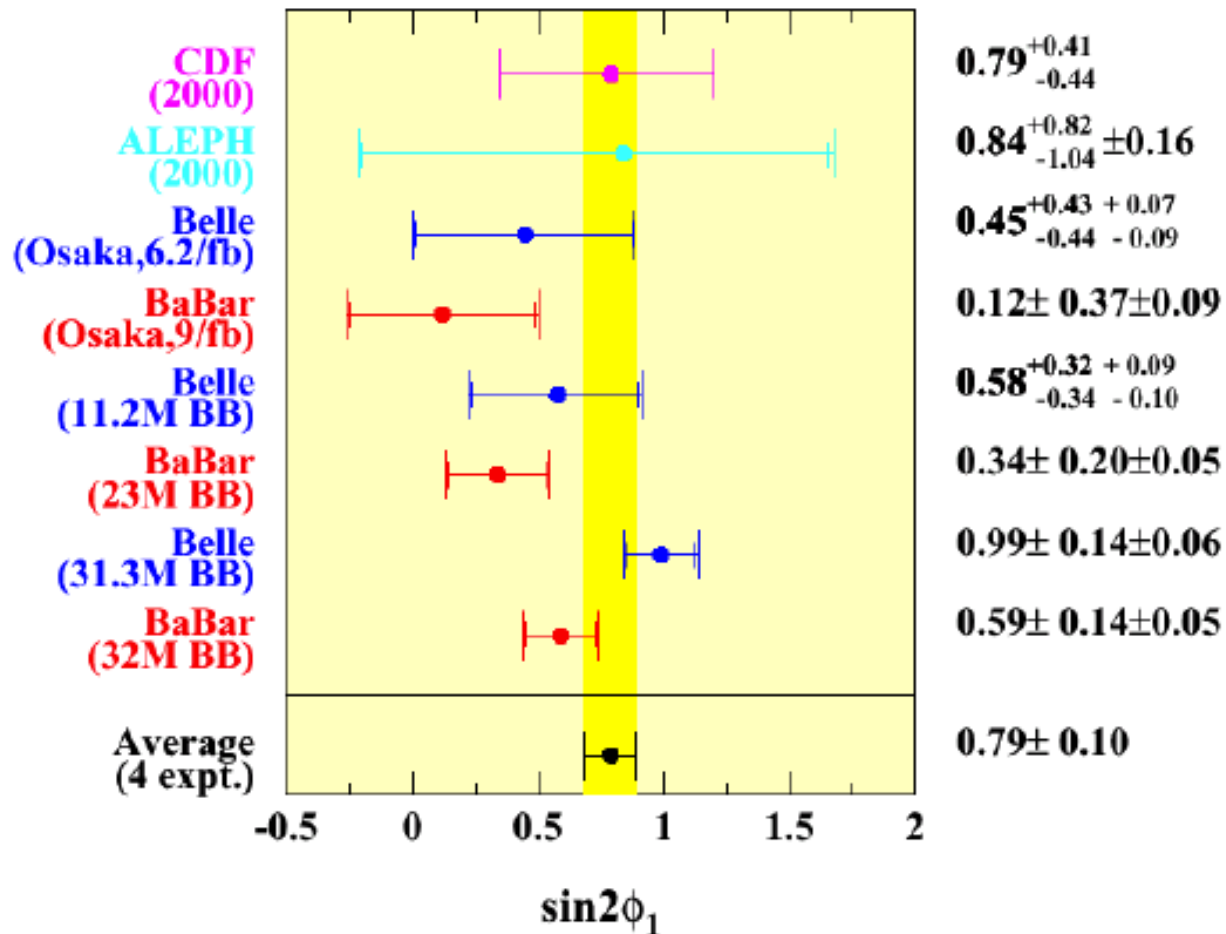

STATUS-Report

5. Februar 2002

