

Statusbericht Belle / Mai 2007

Laurenz Widhallm
(für Christoph Schwanda)

-
- Neues vom KEKB-Beschleuniger, dem Belle Detektor und SuperBelle
 - Highlights der neuen Belle-Physikresultate
 - Status der Wiener Analysen

Integrierte Luminosität

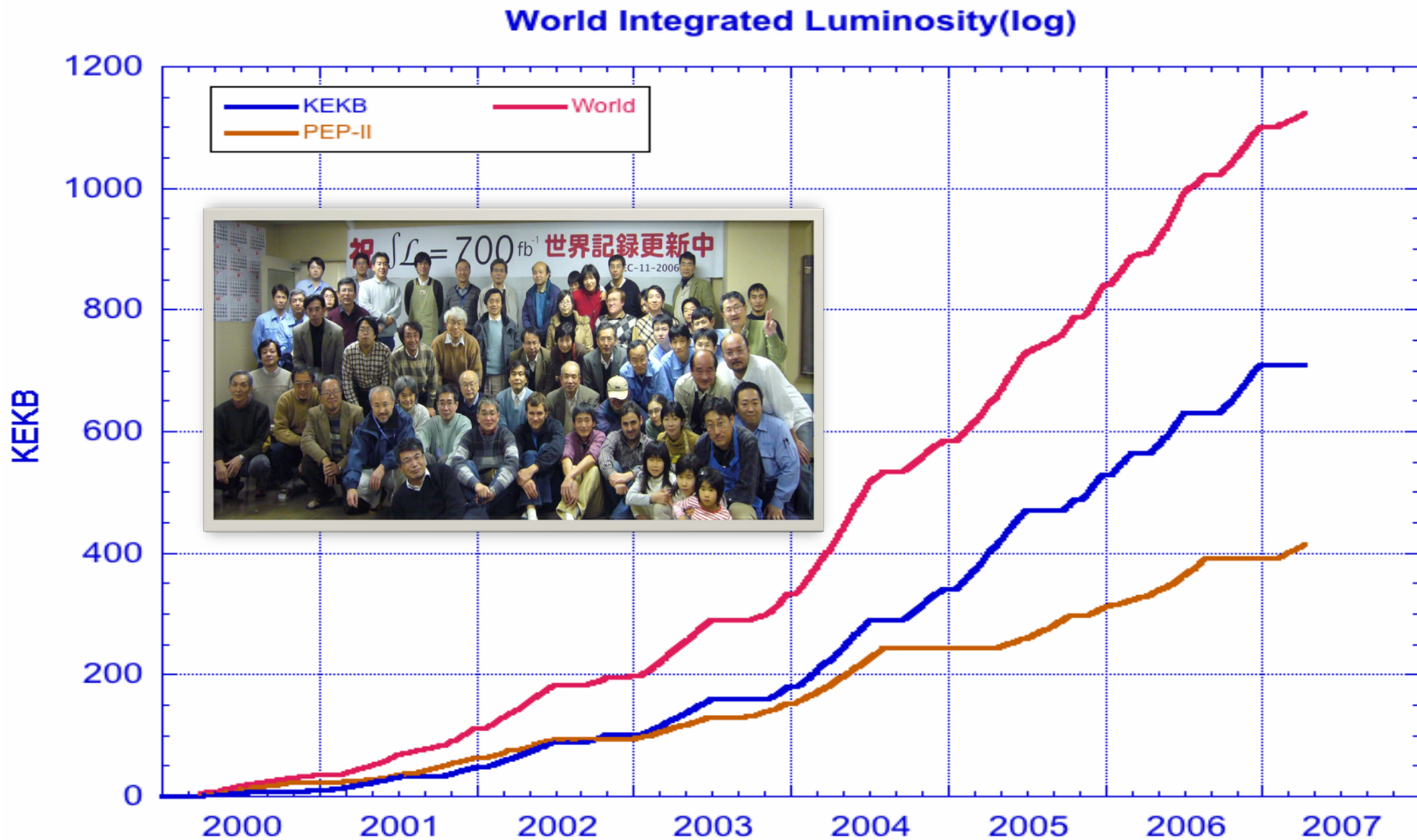

- aufgrund der Studien mit den Crab Cavities dzt. nur sehr geringe Luminosität!

Crab Cavities

- Einbau zweier Crab Cavities erfolgte im Jänner 2007
- commissioning „basically successful“ with and w/o beam
- erster Crab Kick des Beams wurde im Februar beobachtet
- Tests finden derzeit bei sehr niedriger Luminosität statt, eine endgültige Conclusion über die Einsatzbereitschaft der Crab Cavities gibt es noch nicht
- zwei Szenarien: KEKB mit CC @ $400\text{fb}^{-1}/\text{yr}$ oder ohne bei $\sim 200\text{fb}^{-1}/\text{yr}$

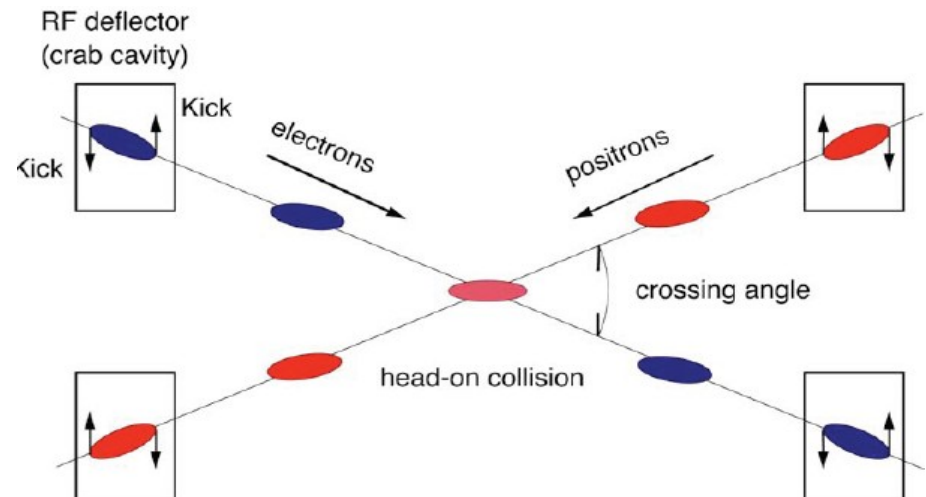

Crab Cavities

Beams have indeed tilted!

- Observation with Streak Cameras (H. Ikeda, et al) -

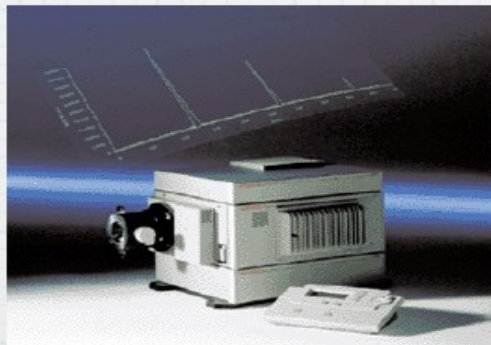
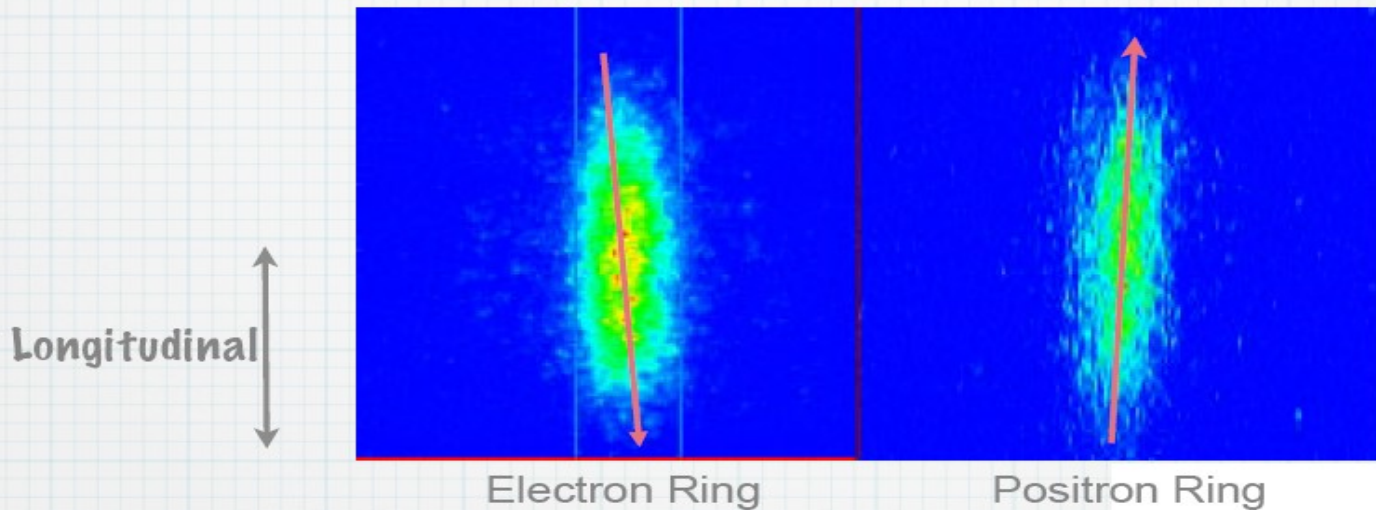

← Streak Camera and its Schematic Diagram →

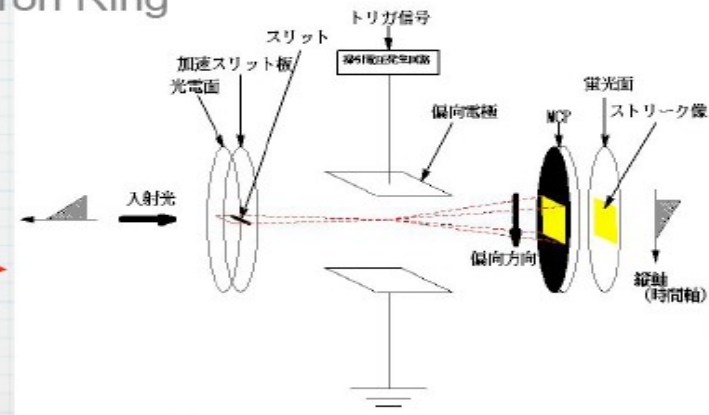

DAQ intrinsic deadtime: Projection (injection VETO(3.5%@10Hz) is NOT included)

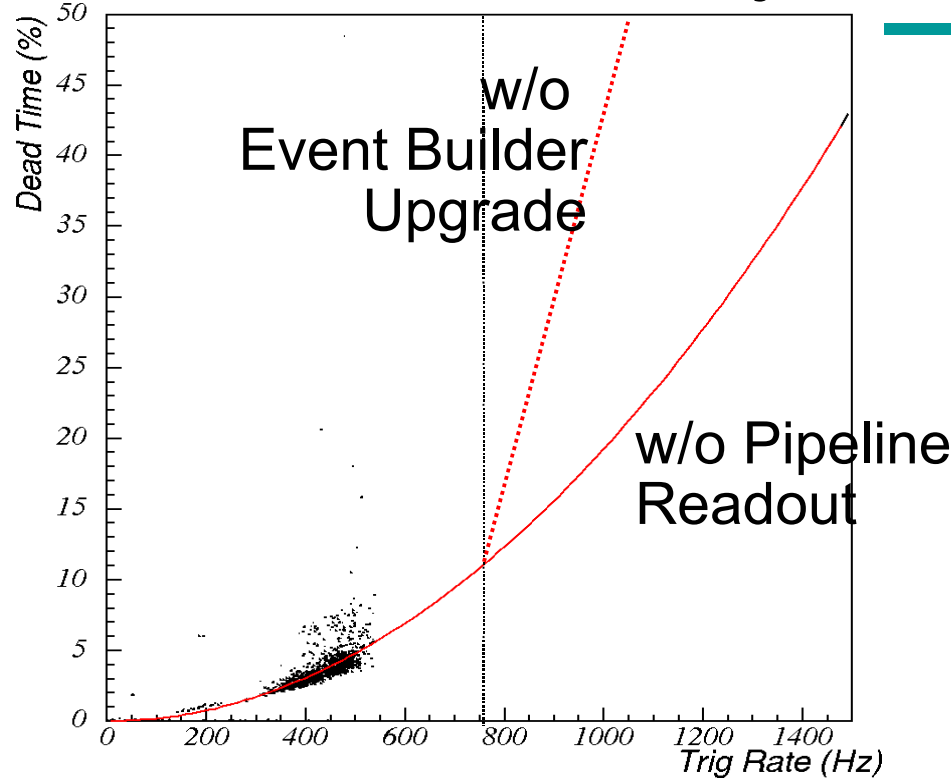

Crab cavity has been installed and tuning is in progress.

L will reach $> 2\sim 3 \times 10^{34} \text{ cm}^{-2}\text{sec}^{-1}$ soon, hopefully.

Trigger rate $> 1\text{KHz}$

DAQ deadtime $> 20\%$ which is unacceptable.

Upgrade of Event Builder : “Dual farm system” ← already done last year

Readout pipelining: need to upgrade all readout subsystems one by one.

Started from CDC this year which has the longest readout deadtime

COPPER based TDC

Idea: Build a TDC module compatible with LeCroy 1877S as possible using COPPER (pipeline platform) + AMT3-TDC FINESSE => **Pipelining of digitizers is possible without modifying frontend electronics**
<- The same signal cable connectors, signal level (ECL)

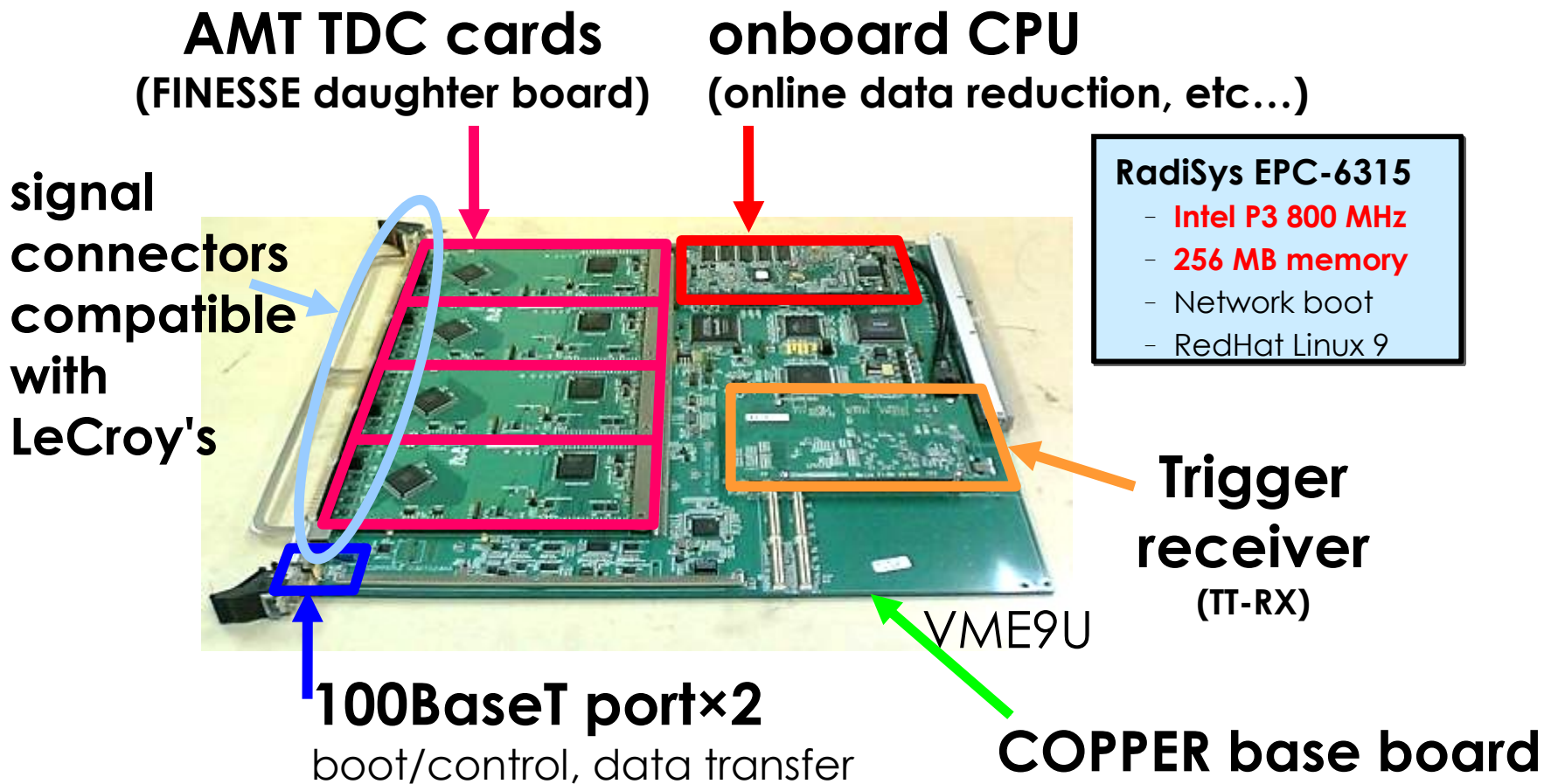

Reduction of readout deadtime after upgrade

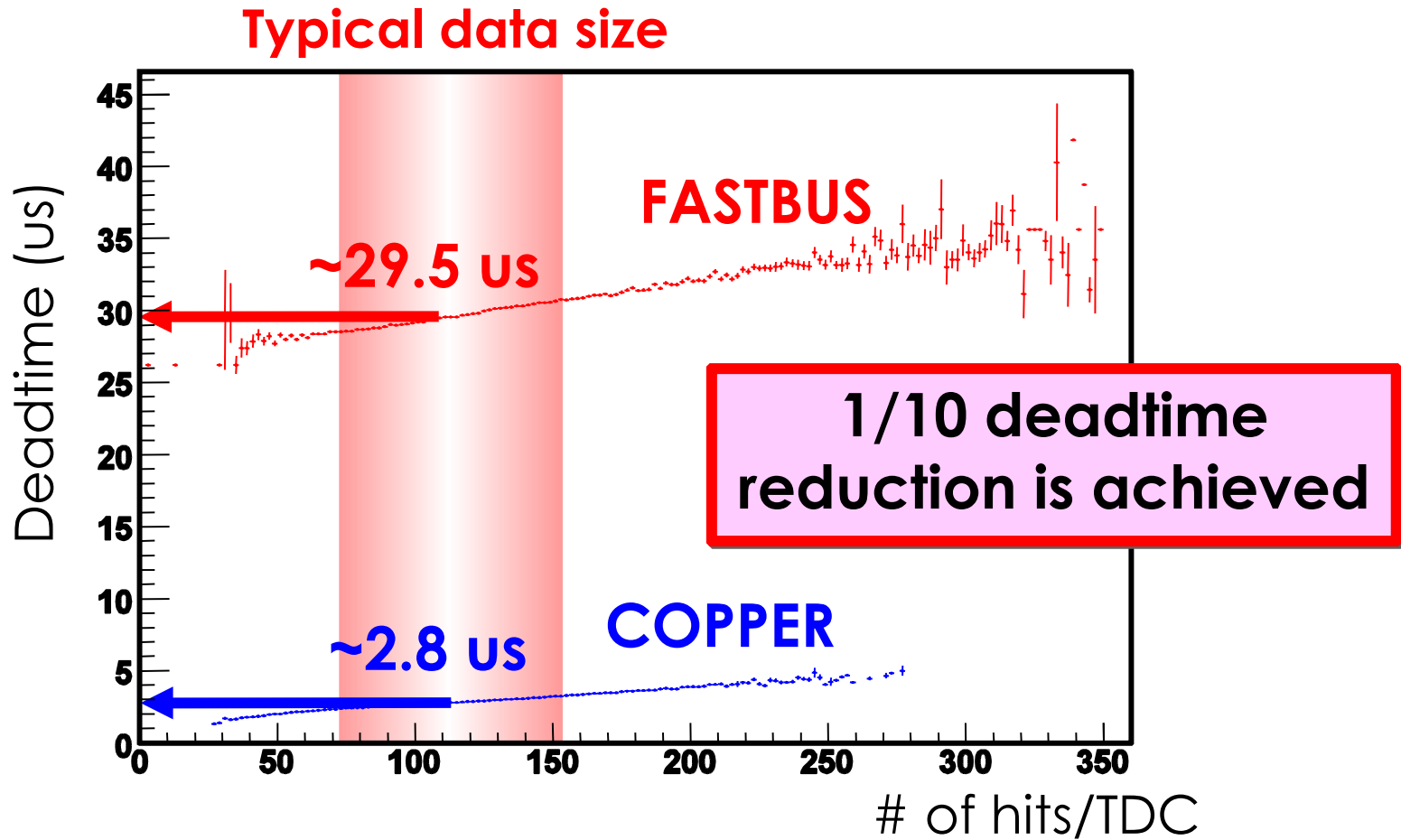

Other sub-detectors

Detector	Before	After
CDC	QT + C-stop Fastbus TDC	QT + Copper TDC (AMT3)
ACC		
KLM		
TRG	C-stop Fastbus TDC	Copper TDC (AMT3)
ECLTRG		
SVD	Peak hold (VA1TA) + FADC	continuous sampling (APV25) + FADC + sparsification on FPGA
TOF	QT + Pulse Stretcher + C-stop Fastbus TDC	HPTDC & FADC
ECL	MQT + C-start Fastbus TDC	Waveform sampling FADC + fitting on FPGA

straightforward
a few challenges

Upgrade one by one as far as budget allows



Crab cavities will be installed and tested with beam in 2006.

$e^+ 4.1 \text{ A}$



The superconducting cavities will be upgraded to absorb more higher-order mode power up to 50 kW.

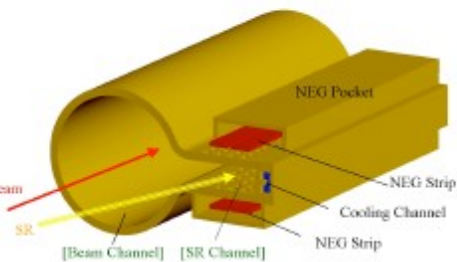

The beam pipes and all vacuum components will be replaced with higher-current-proof design.

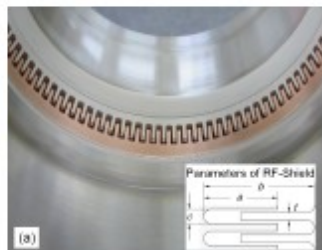

Parameters of RF-Shield

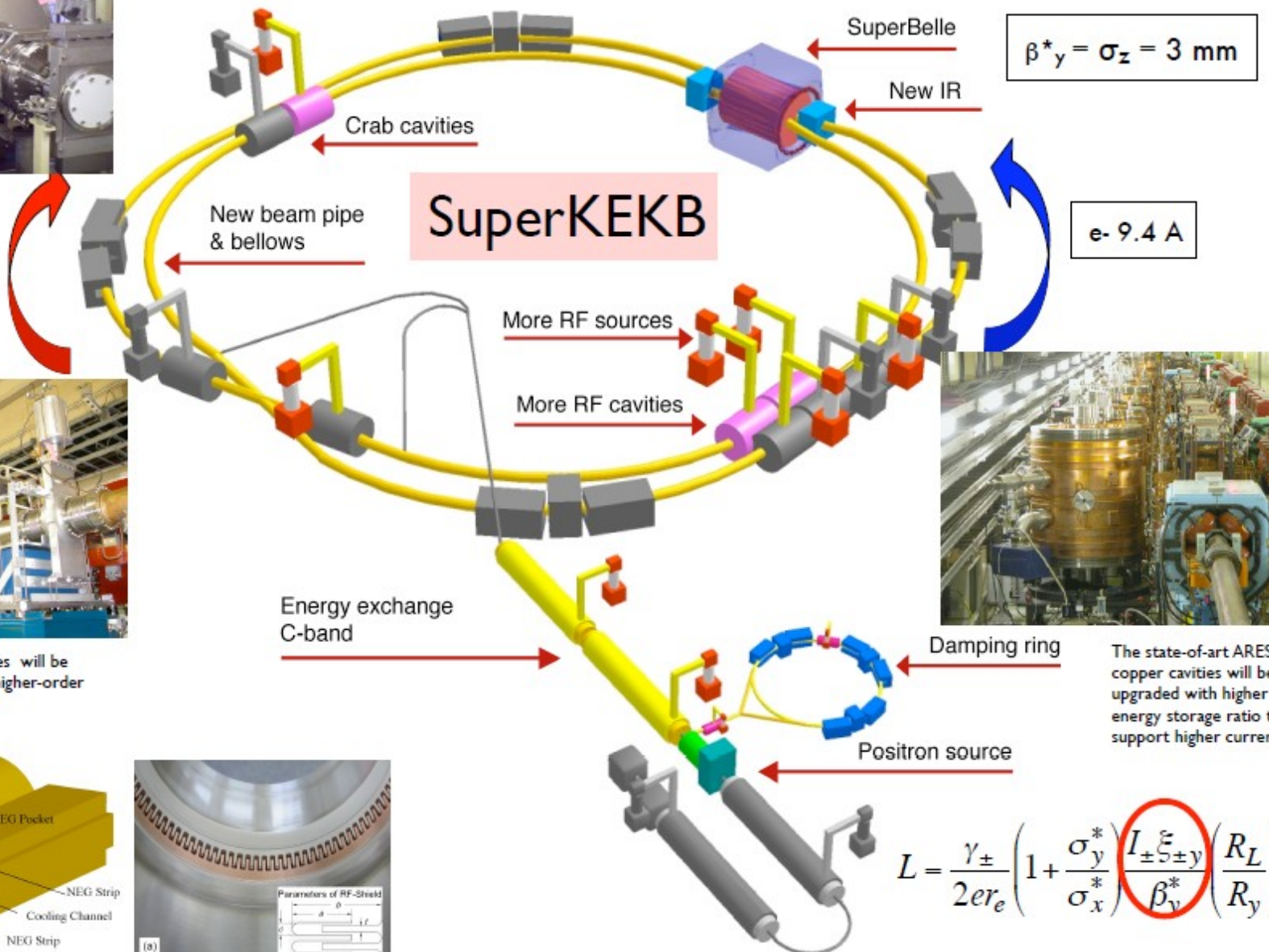

$\beta_y^* = \sigma_z = 3 \text{ mm}$

$e^- 9.4 \text{ A}$



The state-of-art ARES copper cavities will be upgraded with higher energy storage ratio to support higher current.

$$L = \frac{\gamma_{\pm}}{2er_e} \left(1 + \frac{\sigma_y^*}{\sigma_x^*} \right) \left(\frac{I_{\pm} \xi_{\pm y}}{\beta_y^*} \right) \left(\frac{R_L}{R_y} \right)$$

will reach $8 \times 10^{35} \text{ cm}^{-2}\text{s}^{-1}$.

Two approaches to achieve $L \sim 10^{36}$

- High current, high beam-beam parameter
= SuperKEKB

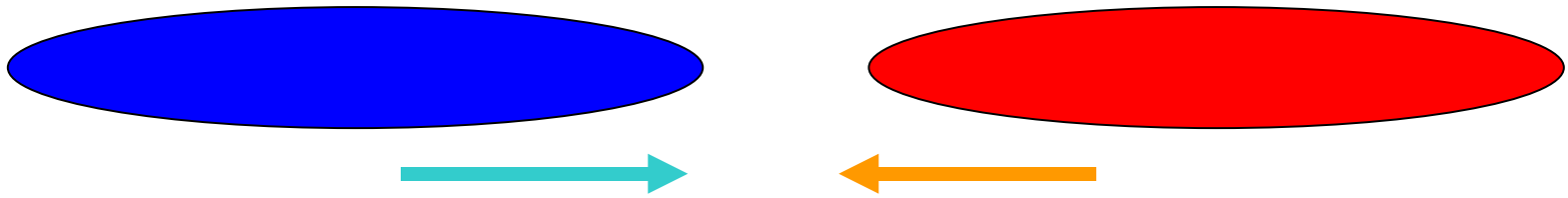

- Low emittance, low beta, low current
= LC SuperB

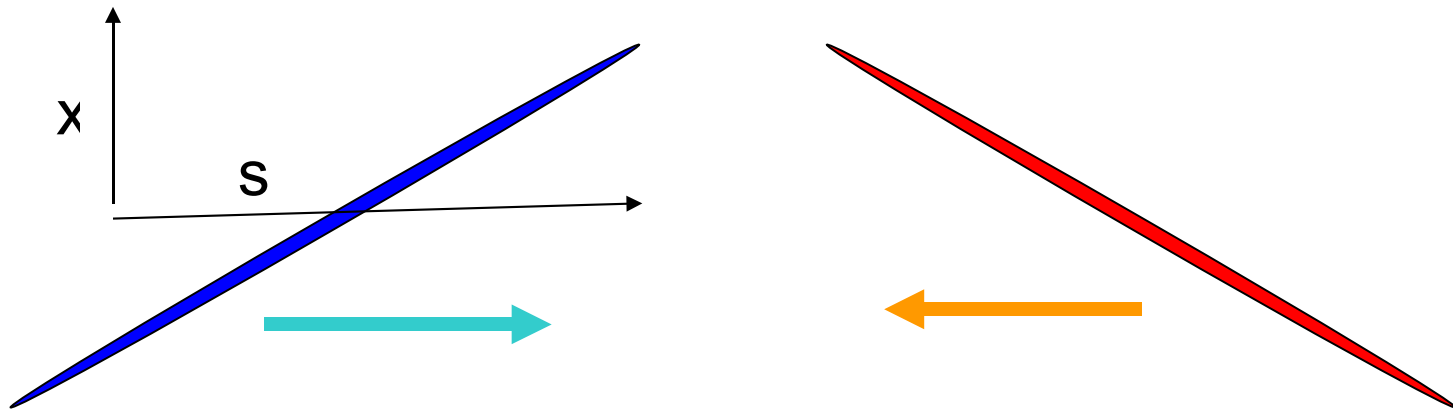

Nano-beam Scheme

- This new idea is proposed for [SuperB by Frascati people](#).
- Low emittance (~ 1 nm) and low beta scheme, so called "**Nano-beam scheme**", is based on crossing angle concepts.
- If we compare between standard short-bunch beams and slender beams with large crossing angle, both cases can give the same luminosity.

(a) standard short-bunch

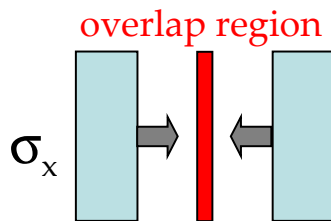

(b) slender beam and crossing angle

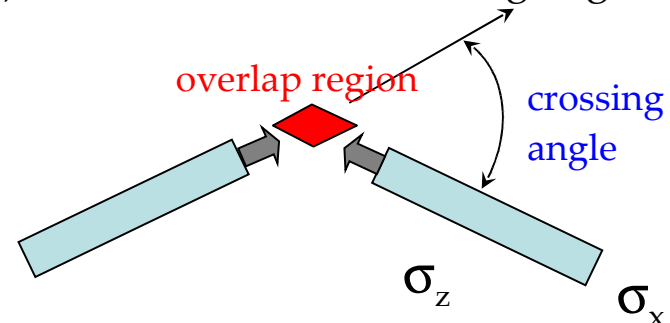

- Small horizontal beam size can be achieved in a ring (see ILC damping ring).
- Luminosity increases with $(1/\text{emittance})$ and is not dependent on bunch length in principle.

Crab Waist Scheme

- Waist position is adjusted by kick from sextupoles to suppress hourglass effect. $\longrightarrow \Delta s \sim x/2\phi_x$
- Particles collide another beam at their waist point (beam size minimum).
- Luminosity gain is factor 2.

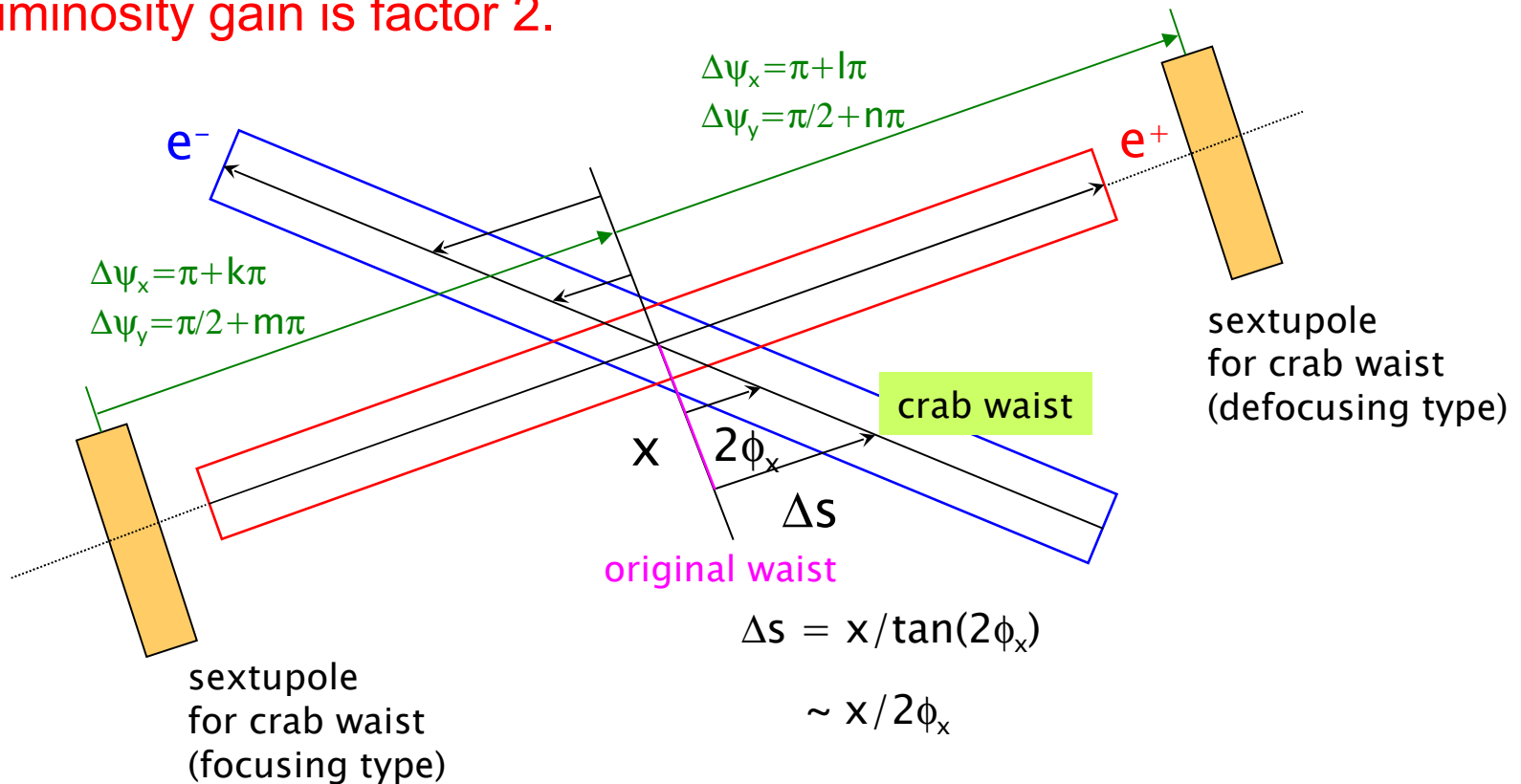

KEKB's approach

- We keep high current approach until finding a solution to dynamic aperture and injection scheme in the low emittance scheme.
- Both crab crossing and crab waist scheme will be tested in the KEKB ring soon.

Proposed schedule

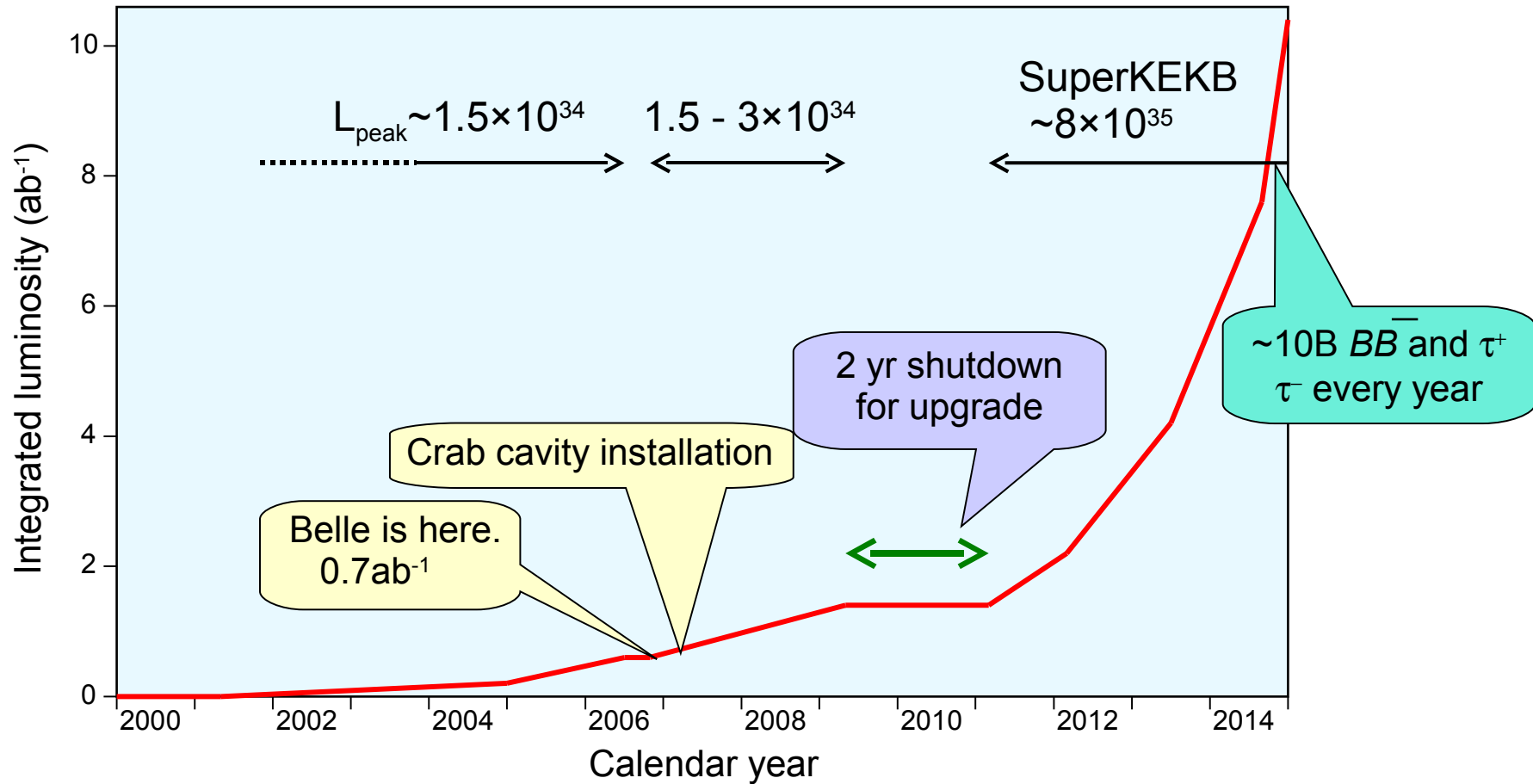

Future of KEKB/Belle

(aus einem Review-Talk von Yamauchi-san vom 20.4.07)

- MEXT understands that KEKB/Belle continues to run until we accumulate 1000 fb^{-1} , which will be achieved by the end of JFY2008.

- Plan after that is open.
 - 1. Quit KEKB/Belle.
 - 2. Continue present KEKB/Belle for more years.
 - 3. Upgrade it to SuperKEKB.Some decision has to be taken very soon.

Consensus in J-HEP community

- Japanese HEP community reached the following agreement in October 2006 after a long debate.
- First priority is to realize ILC, and its R&D should be boosted. On the other hand, flavour physics programs (SuperKEKB, ν and K programs at J-PARC) should be carried out as physics programs before ILC (i.e., 2010's).

Joint effort with Italian SuperB

- Common understanding: there will be at most one Super B Factory built in the world.

soll beides am KEKB getestet werden!

- We have four options:
(high current or low beta) x (KEK or Rome)
None of the options should be thrown away at this point.

- Close communication is going on.
 - Visit each other and telephone meetings.
 - Frequent exchange of the status
 - Joint meeting scheduled in Paris (May 07).
 - Joint workshops to be scheduled sometime in fall 07(?).
 - Joint detector R&D will be arranged.

Belle Physik-Highlights

- weiterhin viele Publikationen...

2 Highlights herausgegriffen:

- Evidenz für $D\bar{D}$ -Mixing
- Bestätigung von Verschränkung (Entanglement) im B-System

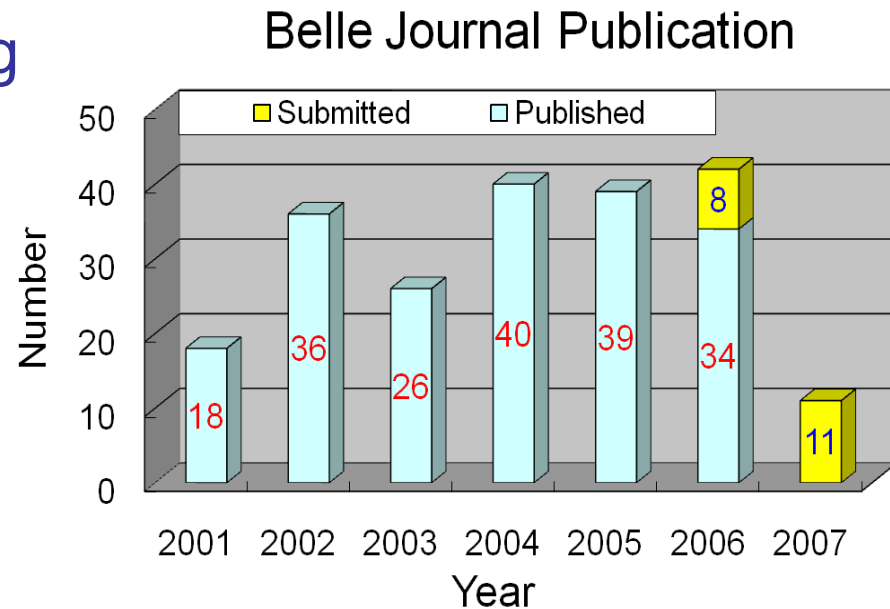

$D^0 - \bar{D}^0$ mixing

Experimentally not observed until March 2007

Two recent Belle measurements

decays to CP final state, $D^0 \rightarrow K^+K^-/\pi^+\pi^-$

decays to hadronic multi-body final state, $D^0 \rightarrow K_S \pi^+\pi^-$

$D^0 \rightarrow K^+K^-/\pi^+\pi^-$

decay time distribution modified from exponential; effective τ changed

$$y_{CP} \equiv \frac{\tau(K^-\pi^+)}{\tau(K^-K^+)} - 1 = y \cos \varphi - \frac{1}{2} A_M x \sin \varphi \stackrel{\text{no CPV}}{=} y$$

D^0 system different than K^0, B_d^0, B_s^0 ; down-type quarks in box diagrams

$$|D_{1,2}\rangle = p|D^0\rangle \pm q|\bar{D}^0\rangle;$$

$$x \equiv \frac{m_2 - m_1}{\Gamma}; \quad y \equiv \frac{\Gamma_2 - \Gamma_1}{2\Gamma};$$

x, y difficult to calculate; SM predictions: $x, y \leq 10^{-2}$

I.I. Bigi, N. Uraltsev, Nucl. Phys. B592, 92 (2001);
A.F. Falk et al., PRD69, 114021 (2004)

$D^0 - \bar{D}^0$ mixing

$$D^0 \rightarrow K^+K^-/\pi^+\pi^-$$

simultaneous fit to t distributions of $K^-\pi^+/K^+K^-/\pi^+\pi^-$

$$\chi^2=1.084 \text{ (ndf=289)}$$

$$y_{CP} = (1.31 \pm 0.32 \pm 0.25) \%$$

evidence for D^0 mixing
(regardless of possible CPV)

search for CPV:

$$A_\Gamma = \frac{\Gamma(\bar{D}^0 \rightarrow K^-K^+) - \Gamma(D^0 \rightarrow K^-K^+)}{\Gamma(\bar{D}^0 \rightarrow K^-K^+) + \Gamma(D^0 \rightarrow K^-K^+)}$$

$$A_\Gamma = (0.01 \pm 0.30 \pm 0.15) \%$$

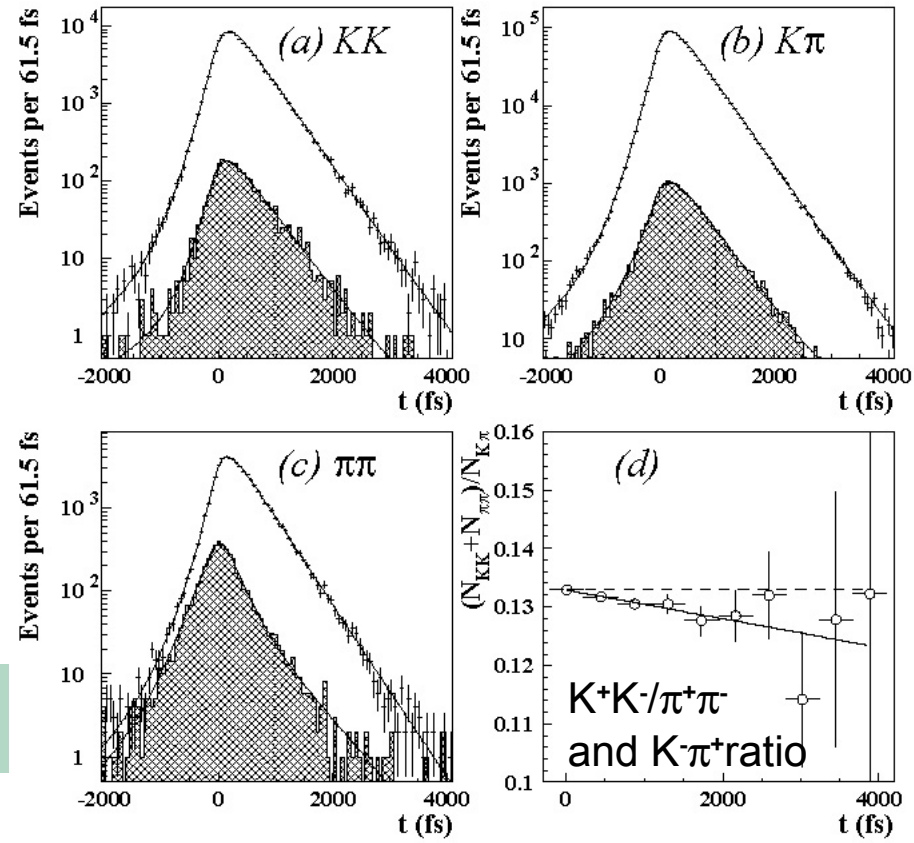

Quantum entanglement

- one of the recent **hot topics** in the BELLE experiment
- investigation of **fundamental QM** properties in **massive particle** systems
- EPR-type **flavor entanglement** in the $B^0 \bar{B}^0$ system
- **recent study** of A.Go and A. Bay studies **possible deviation from QM behavior** for **two specific local realistic (LR) models** of coherence
- like all CP-violation studies **based on time difference Δt** of B^0 decays
 - averaging over **relevant lifetime** of **total 2 particle system**
 - using **strong standard QM MC-assumptions** for

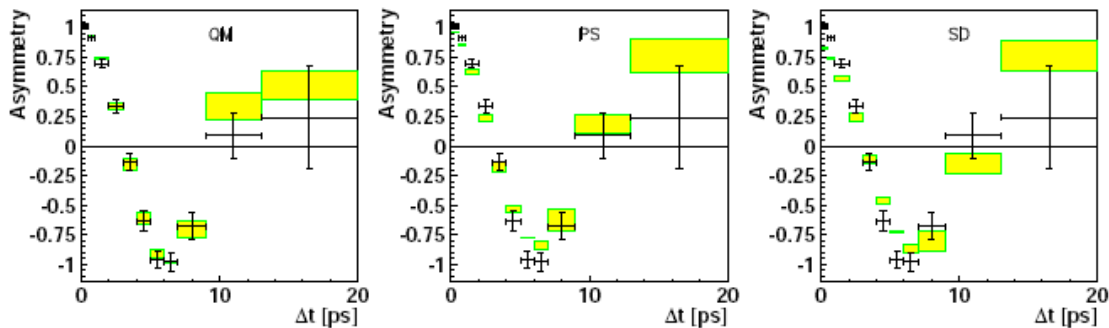

Belle Collaboration
 Belle is an experiment origin of CP violation.
 Introducti

Hot !

Belle Finds Evidence for D^0 - D^0 bar Mixing

[Belle-preprint 2007-18](#), [hep-ex/0703036.v2](#) (to appear in PRL)
 M.Staric's Talk at Moriond 2007 ([pdf](#))
[Short Summary](#), [Non-Technical Summary](#)

Belle Confirms Quantum Entanglement at 10 Billion Electron Volts

Press Release 2007.03.02 [[English](#)], [[Japanese](#)]
[quant-ph/0702267](#) (submitted to PRL)

$$A_{QM}(\Delta t) \equiv \frac{R_{OF} - R_{SF}}{R_{OF} + R_{SF}} = \cos(\Delta m_d \Delta t)$$

$A_{SD}(t_1, t_2)$ and $A_{LR}(t_1, t_2)$

are more complicated terms of the alternative LR models

- **results A.Go/A.Bay:**
 - **entanglement properties** according to QM **confirmed for B^0 mesons**
 - the 2 **alternative LR models** show **bad compatibility with data**

$|V_{cb}|$ from inclusive decays $B \rightarrow X_c l \nu$

Inclusive E_l spectrum

[Phys.Rev. D75, 032001 (2007)]

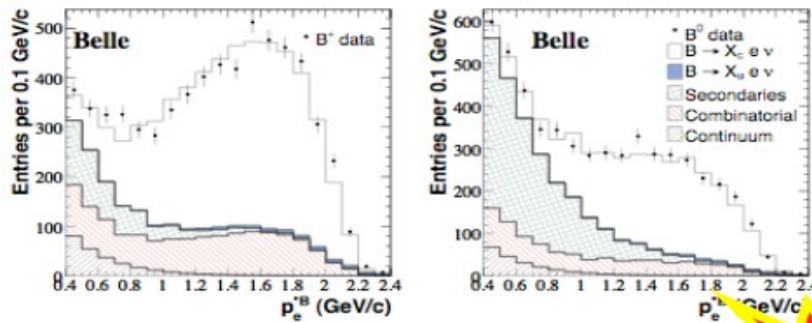

rate

shape

Kinetic running mass

$$|V_{cb}| = (41.93 \pm 0.65_{\text{fit}} \pm 0.07_{\alpha_S} \pm 0.63_{\text{th}}) \times 10^{-3}$$

$$m_b = 4.564 \pm 0.076 \text{ GeV}$$

1S mass

$$|V_{cb}| = (41.49 \pm 0.52_{\text{fit}} \pm 0.20_{\tau}) \times 10^{-3}$$

$$m_b = 4.729 \pm 0.048 \text{ GeV}$$

[hep-ex/0611047]

Inclusive M_X^2 spectrum

[Phys.Rev. D75, 032005 (2007)]

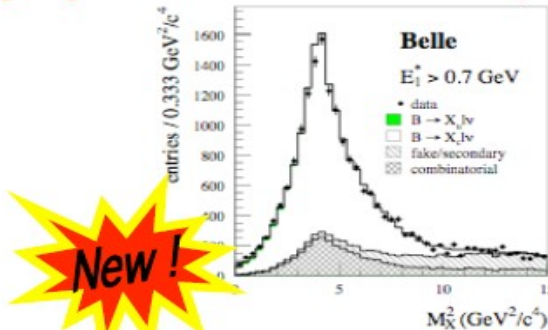

shape



Non-perturbative parameters

shape



$B \rightarrow X_s \gamma$

$D_s \rightarrow \mu\nu$ branching ratio

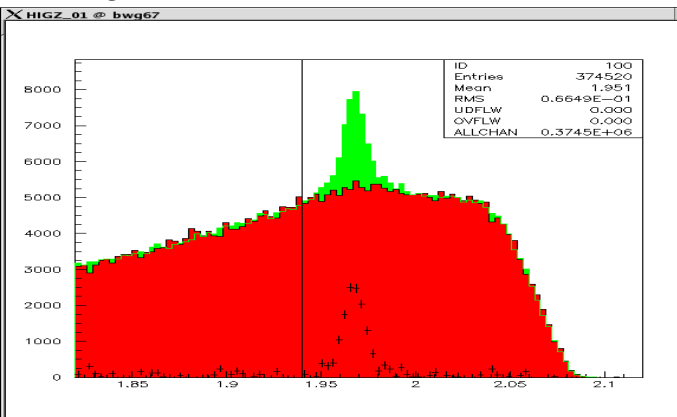

BR([mn])

$$BR = (6.78 \pm 0.76 \pm 0.48_{mcstat}) \times 10^{-3}$$

PRELIMINARY!

- without mcstat
- with mcstat

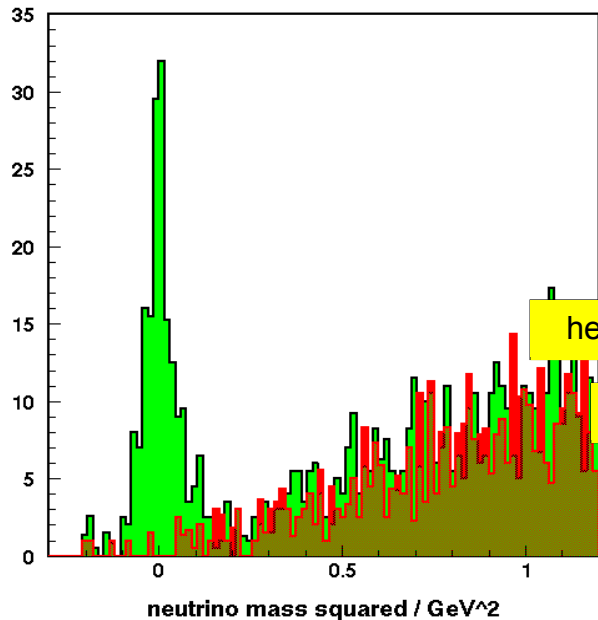
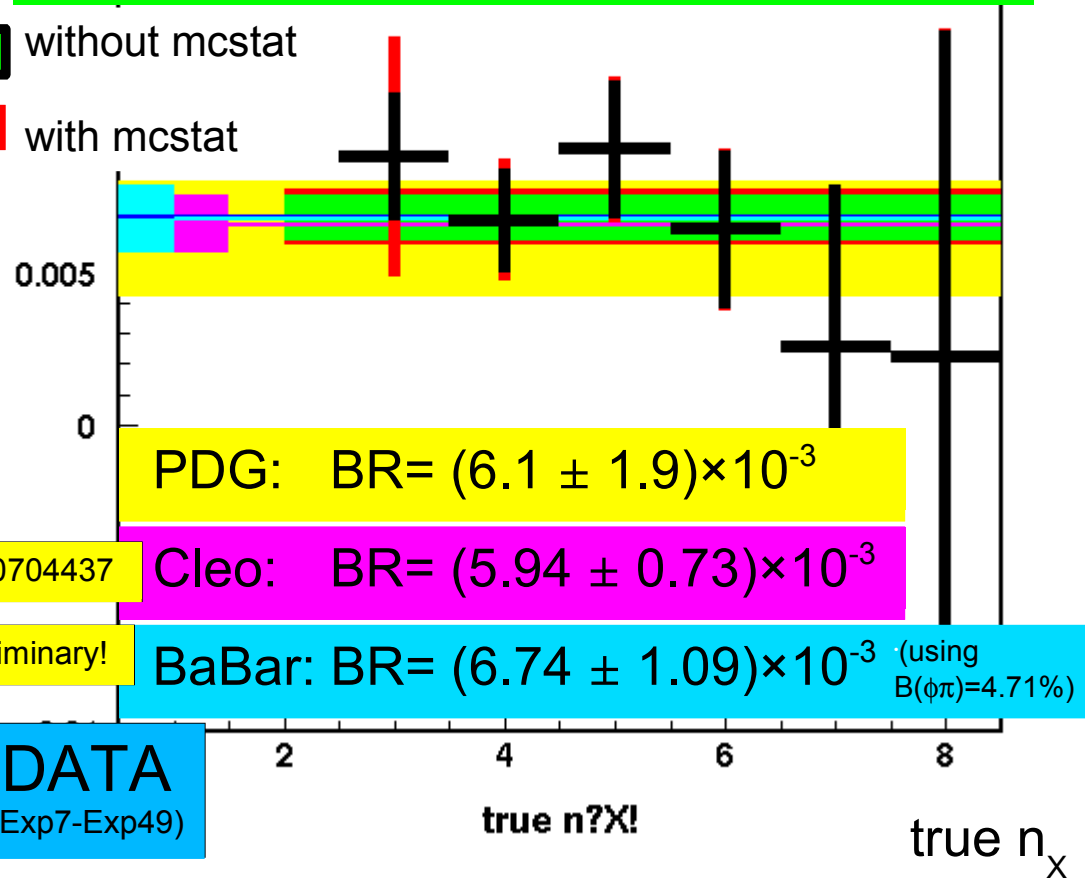

DATA
(Exp7-Exp49)

$D_0 \rightarrow KKX$ inclusive branching ratios

Scheme of reconstructed event topology

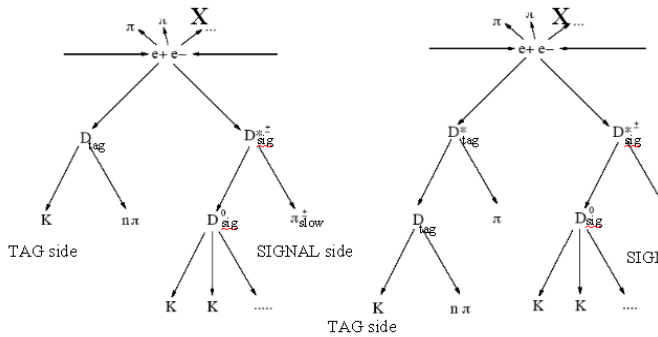

DD* events

D(tag)

D** (signal)

D*D* events

D*(tag)

D** (signal)

missing mass $MM(K^+K^-) = M(X)$ from $D^0 \rightarrow K^+K^-X$

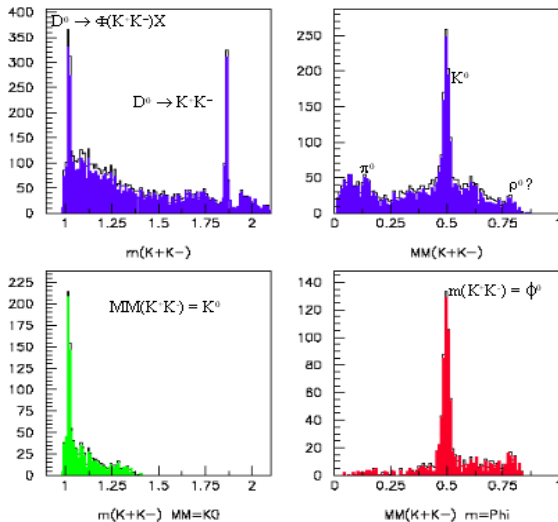

Preliminary Results (stat. errors only)

$$BF(D_0 \rightarrow \Phi(K+K^-)X) = (0.55 \pm 0.04)\%$$

$$BF(D_0 \rightarrow \Phi X) = (1.12 \pm 0.08)\% \quad \text{PDG: } (1.7 \pm 0.8)\%$$

Cleo prel: $(1.0 \pm 0.1)\%$

$$BF(D_0 \rightarrow K+K^-) = (0.38 \pm 0.025)\% \quad \text{PDG: } (0.384 \pm 0.010)$$

$$BF(D_0 \rightarrow \Phi(K+K^-)) = (0.45 \pm 0.05)\% \quad \text{PDG: } (0.42 \pm 0.04)$$

$$BF(D_0 \rightarrow K+K^-K_0) = (0.60 \pm 0.07)\% \quad \text{PDG: } (0.56 \pm 0.09)$$

$$BF(D_0 \rightarrow K+K^- \pi^0) = (0.09 \pm 0.02)\% \quad \text{PDG: } (0.14 \pm 0.04)\%$$

$$BF(D_0 \rightarrow \Phi(K+K^-)\pi^0) \text{ not seen} \quad \text{PDG: } (0.0037 \pm 0.0003)$$

Rough estimate (handfit):

$$BF(D_0 \rightarrow \Phi(K+K^-)\rho^0) = 0.04\% \text{ (error about 50\%)} \quad \text{PDG: } (0.067 \pm 0.006)\%$$

$$BF(D_0 \rightarrow K+K^-\rho^0) \text{ not seen} \quad \text{PDG: } (0.005 \pm 0.007)\%$$

Quantum entanglement

- based on theoretical work of R. Bertlmann and B. Hiesmayr
- more general class of dissipative coherence models
 - assuming arbitrary dissipative process disturbing the entanglement
- derived as part of QM, not outside of it

$$A^{BH}(t_1, t_2, \lambda) = \cos(\Delta m \Delta t) \exp(-\lambda \min(t_1, t_2))$$

experimentally challenging

- based on 2 time parameters t_1 and Δt of B^0 decays, employing "non-mainstream method" for reconstruction
- careful numerical treatment of model necessary

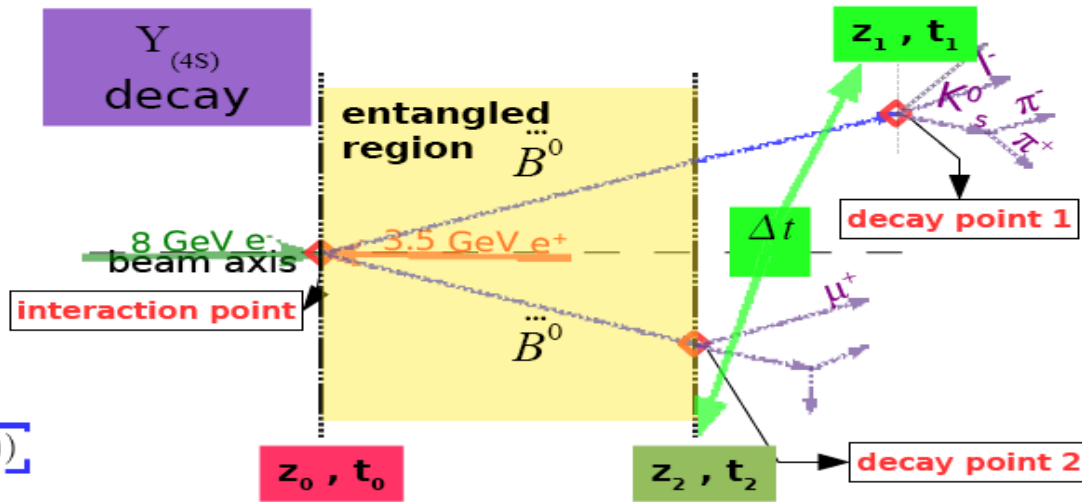
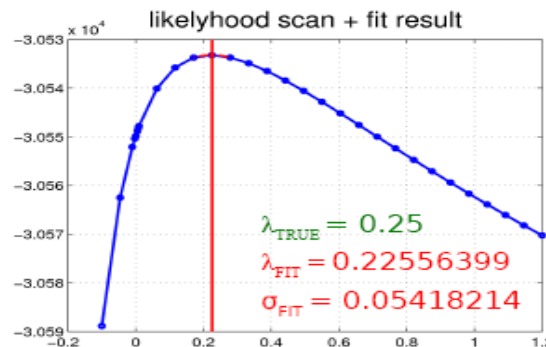

achievements:

- correspondence of results with full detector-MC on signal event level

ongoing:

- background treatment
- search for partial analytic simplifications

final results:

- end of summer

Unsere Neuzuwachs: Kurze Vorstellung

Wolfgang Dungal



- geboren: 1. 8. 1982
- Studium: Technische Physik, TU Wien
 - Oktober 2001 – Jänner 2007
- Diplomarbeit bei Prof. Leeb
 - Theoretische Kernphysik
- seit 1.4.2007: Dissertation am HEPHY
 - Belle Gruppe – Physics analysis